

# Instruction manual of assist trap

## TFA-2000

Thank you very much for purchasing YOSHITAKE assist trap.  
Please read this manual thoroughly before you use the product for safe and correct use of it. Please keep this manual at hand.



日本語



English

— — — — — The meanings of symbols are as follows: — — — — —



**WARNING**

If users handle the device incorrectly, serious injury or death could result.



**CAUTION**

If users handle the device incorrectly, bodily injury and damage to the equipment could result.

### Table of contents

1.	Specifications	1
2.	Structure and Operation	
2.1	Structure	1
2.2	Operation	2
3.	Capacity diagram	3~4
4.	Installation procedure	
4.1	Example of piping diagram	4
4.2	Remarks on installation	5~6
5.	Operating procedure	
5.1	WARNING and CAUTION related to operation	7
5.2	Product starting method	7
6.	Maintenance and inspection	
6.1	WARNING and CAUTION for maintenance and inspection	7~8
6.2	Daily inspection and periodic inspection	8
6.3	Periodic replacement	8~9
6.4	Troubleshooting	9~11
6.5	Disassembly and assembly procedure	12~17
6.6	Replacement procedure of parts	17~18
7.	Waste	18

After-sales service

# YOSHITAKE

## 1. Specifications

Model	TFA-2000
Nominal size	25A
Application	Steam condensate, Non-hazardous fluid
Motive fluid	Steam, Air
Max. working pressure	0.5MPa
Motive pressure	0.03~0.5MPa
Motive differential pressure	(Back pressure + 0.03MPa) ~ 0.5MPa
Max. working temperature	160°C
Connection	JIS Rc
Check valve at inlet side	Built-in (Swing type)
Check valve at outlet side	Externally attached (Use check valve SCV-2 or SCV-3 (25A) that is sold separately.)

## ⚠ CAUTION

- (1) Before you use the product, check the contents of the name plate attached to the product and specification of the model you ordered.  
 ※If the product is not correct, contact us before you start to use it.

## 2. Structure and Operation

### 2.1 Structure

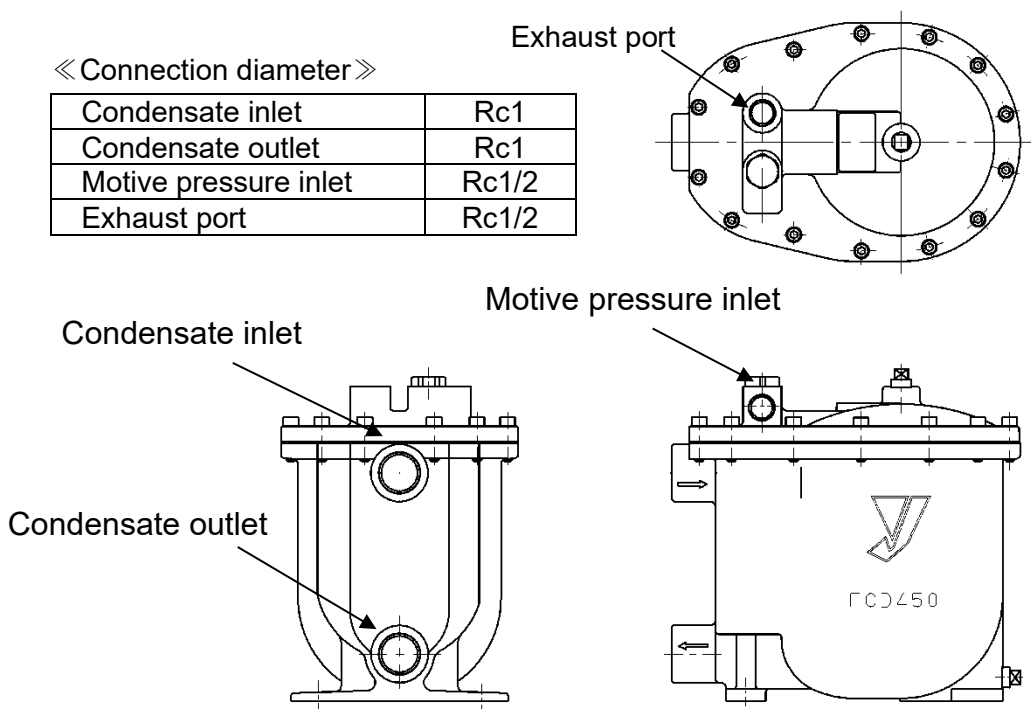

## 2.1 Operation (Refer to Drawing for the names and numbers of the parts.)

### [Trap operation]

If the condensate flows from the condensate inlet through the check valve (8) to the body (1), float (P) (10) is moved up by the ascending force. In connection with the movement, valve (P) (3) opens. If the pressure at the inlet side is larger than the back pressure on the product exit side, condensate is removed in this condition. (See Fig. 2.)

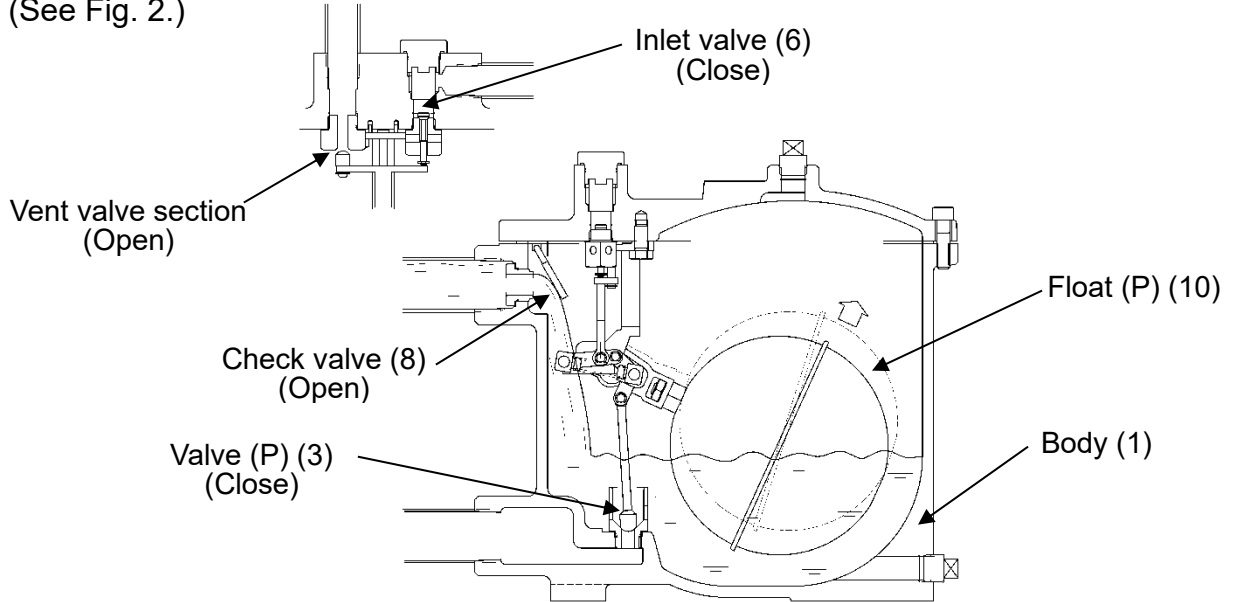

Fig. 2

### [Assist operation]

If the pressure at the inlet side is smaller than the back pressure at the product outlet side, condensate is accumulated in the body. When the condensate level ascends to the float (P) level, the inlet valve (6) opens and the vent valve section of valve (P) closes. When the inlet valve opens, the motive pressure is applied to the body and the check valve is closed to shut up the condensate. The condensate in the body is fed to the outlet side and removed. When the condensate is removed, float (P) moves down depending on the water level in the body. When the float (P) reaches the specified level, the inlet valve closes and the vent valve section of valve (P) opens. The internal pressure is removed from the vent valve and the trap operation condition is recovered. (See Fig. 3.)

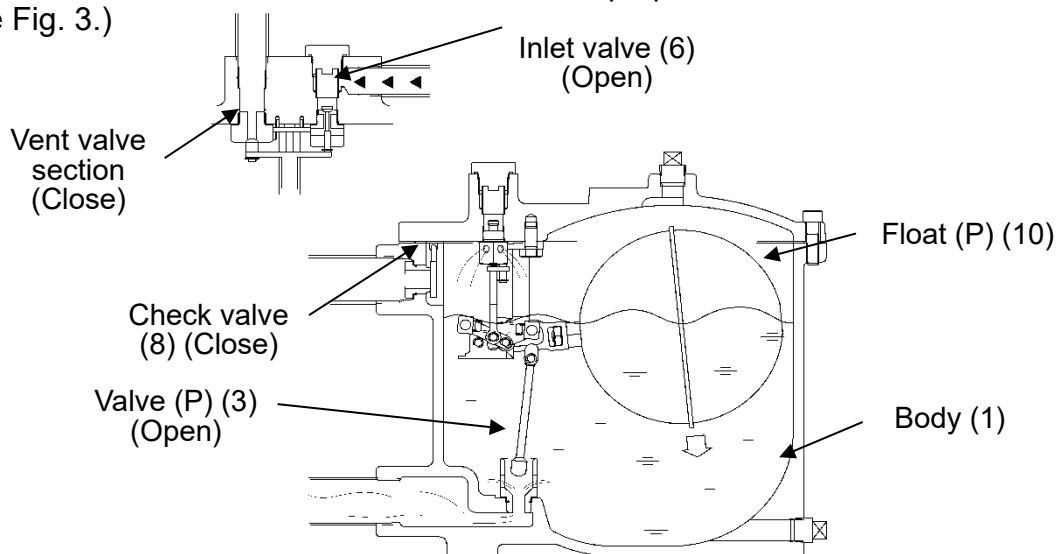

Fig. 3

### 3. Capacity diagram

\* Discharge capacity during trap operation

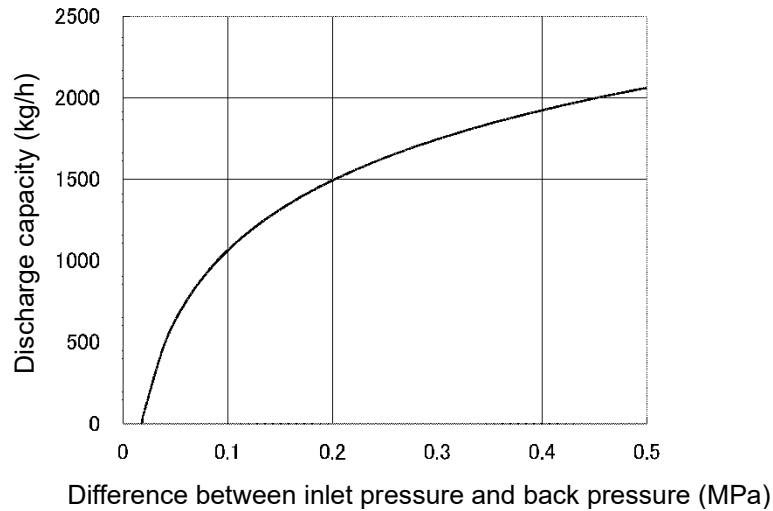

Fig. 4

In trap operation, the discharge capacity depends on the difference between the condensate inlet pressure and back pressure (condensate outlet pressure). That is, if the condensate inlet pressure is 0.5 MPa and the pressure at the outlet side is 0.2 MPa, the amount of condensate when the pressure difference is 0.3 MPa is applicable.

The safety rate shall be multiplied by 2 or 3 when selecting the capacity.

\* Discharge capacity during assist operation

[When the flow-in height (inlet pressure) is 300 mm (=3 kPa) from the assist trap bottom]

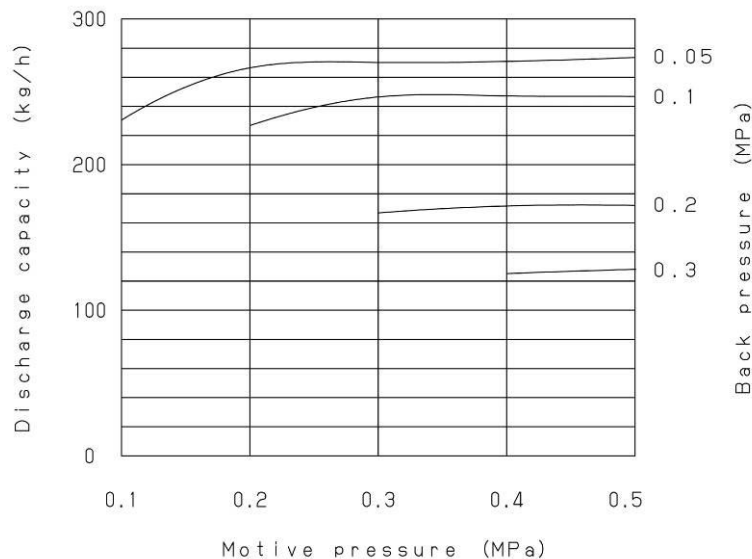

Fig. 5

The assist operation is available only when the condensate inlet pressure is equal to or lower than the back pressure (condensate outlet pressure). The discharge capacity changes depending on motive pressure and back pressure. The discharge capacity depends on the flow-in height (inlet pressure). Multiply the correction coefficient shown in Table 1.

Table 1. Correction coefficient of assist operation capacity

Flow-in height (mm)	Correction coefficient
250	0.65
300	1.0
400	1.1

#### 4. Installation procedure

##### 4.1 Example of piping diagram

<<Application>> Example of drain stagnation prevention measures for air conditioners.

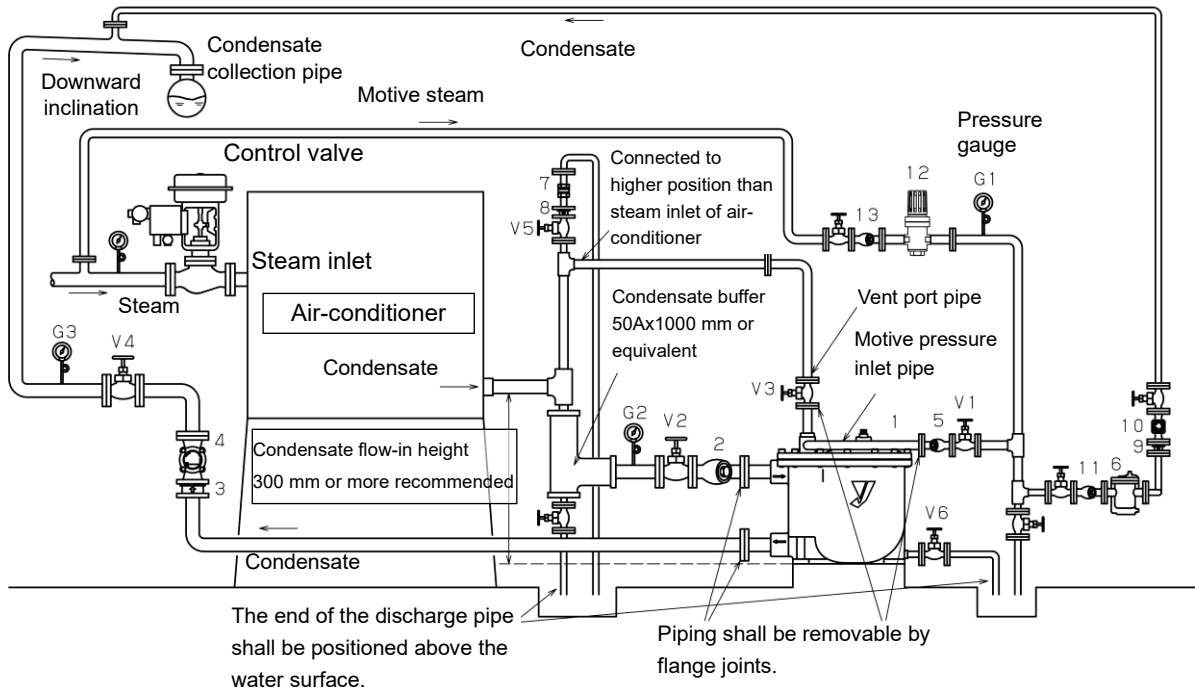

※There is a possibility that the inside of the heat exchanger becomes vacuum pressure by the usage condition.

No.	Name	No.	Name	No.	Name
1	Assist trap TFA-2000 25A	2	Strainer SY-40 25A (80 mesh)	3	Check valve SCV-3 25A
4	Sight glass SLM-1F 25A	5	Strainer SY-40 15A (80 mesh)	6	Steam trap TB-20F 15A
7	Air vent TS-5V 15A	8	Check valve SCV-3 15A	9	Check valve SCV-3 15A
10	Sight glass SLM-1F 15A	11	Strainer SY-40 15A (80 mesh)	12	Pressure reducing valve GD-30 15A
13	Strainer SY-40 15A (80 mesh)	V1	Manual valve BSV-10F 15A	V2	Manual valve BSV-10F 25A
V3	Manual valve BSV-10F 15A	V4	Manual valve BSV-10F 25A	V5	Manual valve BSV-10F 15A
V6	Manual valve BSV-10F 15A				

Fig. 6

## 4.2 Remarks on installation

### ⚠ CAUTION

- (1) Before installing the product, clean the pipe inside completely to remove dust and scale. When connecting the product to pipes, note that the sealing agent and seal tape do not enter the product.
  - \* If the pipes are not cleaned completely, dust or the like might hinder proper operations of the product.
- (2) Check the condensate inlet, condensate outlet, motive pressure inlet, and exhaust port before connecting pipes. (See Fig. 1.)
  - \* Connect pipes correctly; otherwise, the product does not function properly.
- (3) Face the exhaust port upward and install the product horizontally.
  - \* Install the product in the correct direction; otherwise, the product does not function properly.
- (4) Connect pipes securely.
  - \* If pipes are not connected securely, fluid might leak from the connection sections due to vibration, resulting in burning or injury.
- (5) Flange joints shall be used for piping connections. (Refer to 4.1, Example of piping diagram.)
  - \* Unless flange joints are used, the piping cannot be removed, or removal will require a considerable amount of time during repair, maintenance, disassembly, and assembly.
- (6) Do not apply any shocks by the water hammer or the like. Do not use the on-off valve before or after the product.
  - \* If excessive shock is applied, the product might be damaged and fluid blows out, resulting in burning or injury.
- (7) Do not disassemble the product unless necessary.
  - \* Failure to follow this notice may hamper proper operation of the product.
- (8) Attach the strainer before the condensate inlet and motive steam port. (Refer to 4.1 Example of piping diagram.)
  - \* If the strainer is not attached, dust or the like might hinder proper operations of the product.
- (9) Attach the check valve (SCV-2 or SCV-3 25A) to keep the discharge capacity at the condensate outlet side. Note the direction of the check valve. (See Fig. 7.)

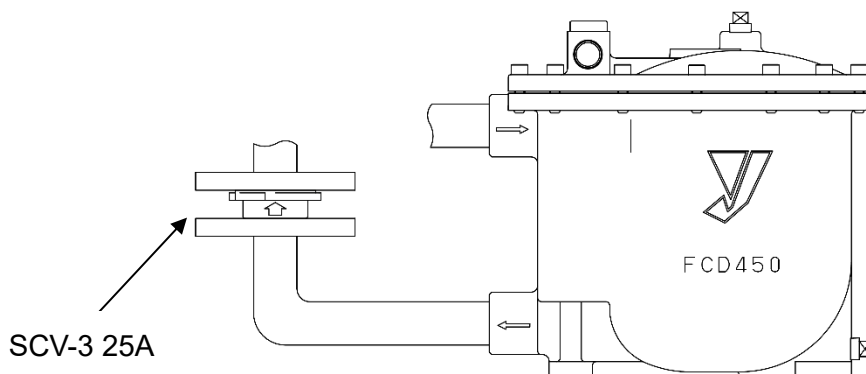

Fig. 7 (Example)

(10) Attach the steam trap to the motive steam pipe for discharging. (See Fig. 8.)

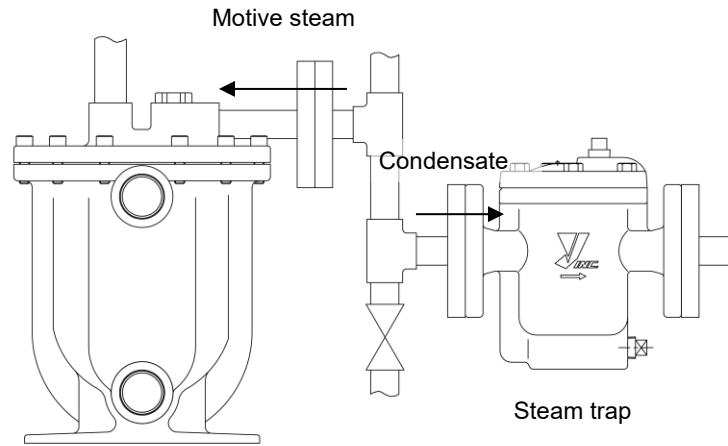

Fig. 8

(11) Provide the space for maintenance required for disassembling or correcting the product. (See Fig. 9.)

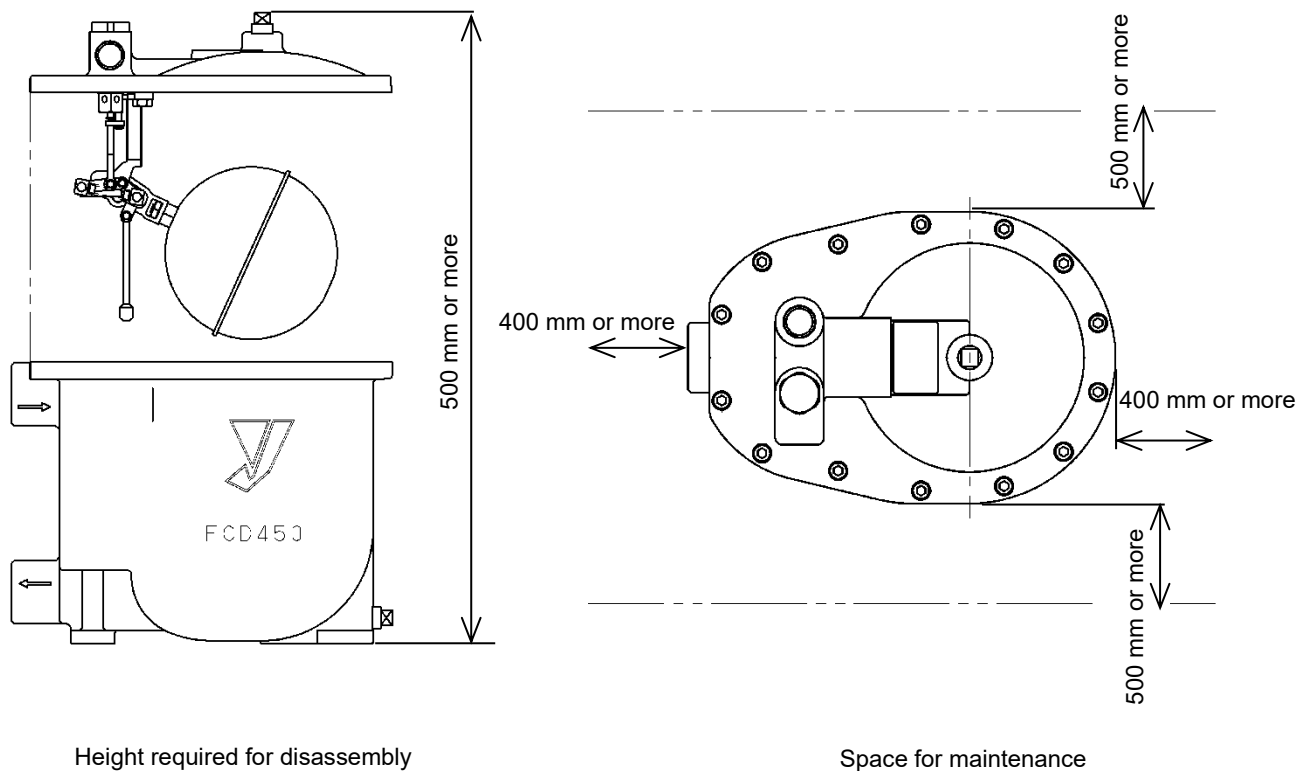

Fig. 9

## 5. Operating procedure

### 5.1 WARNING and CAUTION related to operation

#### WARNING

- (1) Do not touch the product by bare hands when steam is flowing.  
\* Failure to follow this notice may cause burn or injury.
- (2) Confirm that pipe joints are connected securely and not unstable before letting the steam flow.  
\* Failure to follow this notice may cause blowout of steam or condensate, resulting in burning.

#### CAUTION

- (1) Open stop valves on pipes slowly to prevent water hammer.  
\* Sudden opening of stop valves may cause hunting or water hammer, damaging the devices.

### 5.2 Product starting method

Refer to Fig. 6 Example of piping diagram for the symbols and numbers of the stop valves. If water hammer occurs, stop the operation immediately and close the operated stop valves.

- 1: Open the stop valve V4 at the condensate outlet side slowly and completely.
- 2: Open the stop valve V3 of the exhaust port (Equalizer line) slowly and completely.
- 3: Open the stop valve V1 at the motive pressure inlet slowly. Confirm that the motive steam does not flow in the exhaust port or pipes at the condensate inlet side using pressure gauge G2, and open V1 completely.
- 4: To discharge air from air vent 7 through the condensate inlet pipes, open the stop valve V6 slowly and completely. After that, open the stop valve V2 at the condensate inlet side slowly and completely.
- 5: The starting operation is completed if the assist trap performs trap operation or assistance operation and it is confirmed that the condensate is fed using sight glass 4.

## 6. Maintenance and inspection

Most failures of the product are caused due to foreign materials in the pipes. Be especially careful to foreign materials in the pipes. We charge for repair of product failures caused by catching of foreign materials at the customer's site.

### 6.1 WARNING and CAUTION for maintenance and inspection

#### WARNING

- (1) Before starting periodic inspection or exchange of parts, confirm that the pressure in the product or pipes is the atmosphere pressure and the product is cooled down so that it can be touched with bare hands.  
\* If the pressure is high, you might get injured due to remained pressure in the product or pipes. If the temperature is too high, you might get burned.
- (2) If leakage from the joint between the body and cover is observed, replace the gasket with a new one, without re-tightening hex socket head cap bolts.  
\* Re-tightening of hex socket head cap bolt may damage the gasket, causing steam blowout and burn.

#### CAUTION

- (1) Perform periodic inspection to maintain product functions and performance.  
 \* General users should ask experts (staff of facility management/engineering companies, etc.) to perform periodic inspection.
- (2) If the operation is halted for a long period of time, perform periodic inspection before restarting the operation. After that, restart the operation, following 5. Operating procedure.  
 \* The product might malfunction due to rust in the product or pipes.

## 6.2 Daily inspection and periodic inspection

Perform daily and periodic inspection and periodic replacement to maintain product functions and performance.

### ●Daily inspection (1/day, See Fig. 6.)

Inspection items	How to inspect	Countermeasures to failures	
Motive pressure	Check that the pressure is 0.5 MPa or less using the pressure gauge G1.	Adjust the motive pressure.	
Condensate discharge condition	Check the condition visually using the sight glass 4.	(1) Condensate is not removed.	Refer to 6.4 Troubleshooting.
		(2) Continuous blowout.	
Outside leakage	Confirm by visual check.	Refer to 6.4 Troubleshooting.	

### ●Periodic inspection

(Check the following items once a year in addition to the daily inspection items. See delivery drawings for the parts numbers.)

Inspection items	Method	Countermeasures to failures	Countermeasures
Switching of float (P) (10)	<ol style="list-style-type: none"> <li>1. Close all stop valves in the pipes connected to the product.</li> <li>2. Remove the plug (R3/8) (21) attached to the cover, and supply water from there compulsively.</li> <li>3. Confirm the clicking sound issued when the valve (P) (3) is switched.</li> <li>4. Remove the plug (R3/8) (21) attached to the bottom of the body, and remove water from there compulsively.</li> <li>5. Confirm the clicking sound issued when the valve (P) is switched.</li> </ol>	If the valve is not switched, exchange the valve (P) and float (P).	Refer to 6.6.2 or 6.6.3.
Clogging of strainer (15)	Disassemble the strainer and check it visually	If the strainer is clogged, clean or exchange it.	Refer to 6.6.7.

## 6.3 Periodic replacement

The following is the recommended timing of replacement of parts to maintain the product functions and performance. Periodically exchange the parts at the specified interval.

 **CAUTION**

(1) Periodically exchange the parts at the specified interval.

\* The product might malfunction if the parts are not periodically exchanged.

●Periodic exchange parts list

Parts name	Recommended replacement timing
Valve (P)	Whichever earlier between 2 years and 100,000 times of switching operations
Float (P)	Whichever earlier between 2 years and 100,000 times of switching operations

(2) Do not drop parts during disassembly. Put disassembled parts on soft cloth to prevent damages.

\* If the parts are damaged, the product might malfunction.

(3) Use regular parts for replacement. Never remodel the product.

\* If the product is remodeled, you might get burned or injury due to product damage, steam, condensate, or abnormal operation.

(4) Do not reuse old parts.

\*If the parts are reused by mistake, the product might malfunction.

#### 6.4 Troubleshooting (See Fig. 6 for the symbols and numbers of the stop valve.

See drawing for the parts numbers.)

Failure condition	Cause of failure	Countermeasures
Condensate is not removed.	Stop valve V2 at drain inlet is closed.	Open stop valve V2.
	The drain inlet and exit are attached in the opposite direction.	Set the pipe in the correct direction. (See Fig. 1.)
	The motive pressure inlet and exhaust port are attached in the opposite direction.	Set the pipe in the correct direction. (See Fig. 1.)
	Strainer 2 at the drain inlet is clogged up.	Disassemble the strainer, and clean the screen.
	Stop valve V4 at the drain exit is closed.	Open stop valve V4.
	Stop valve V3 at the equalizer line is closed.	Open stop valve V3.
	The motive pressure is insufficient compared to the back pressure.	Adjust the pressure to the specified one.
	Stop valve V1 of the motive steam pipe is closed.	Open stop valve V1.
	Strainer 5 of the motive steam pipe is clogged up.	Disassemble the strainer 5, and clean the screen.
	Air vent 7 is damaged.	Exchange air vent 7.
	The motive pressure exceeds the specified range.	Adjust the motive pressure to the specified one. (Refer to 1. Specification.)

Failure condition	Cause of failure	Countermeasures
Condensate is not removed.	The check valve 3 at the condensate outlet is attached in the opposite direction, or does not open.	Attach the valve in the correct direction. (See Fig. 7.) If the valve does not open, replace it.
	Product strainer (15) is clogged up.	Disassemble strainer (15) and clean it. (Refer to 6.6.7.)
	The vent valve section of valve (P) (3) leaks.	Disassemble the product. If scale is caught at the vent valve section of valve (P) (3), clean it. If the parts are defective such as flaws, replace valve (P). (Refer to 6.6.3.)
	The check valve (8) is fixed, and does not open. Or, foreign materials are caught and the valve is not completely closed.	Confirm that there is no pressure in the product. Disassemble the product and clean check valve (8). (Refer to 6.6.6)
	Steam leaks from the set of inlet valve (6), (7), (23).	Disassemble the product, and replace the set of inlet valve (6), (7), (23). (Refer to 6.6.4)
	Float (P) (10) is damaged.	Disassemble the product, and replace float (P) (10) (Refer to 6.6.2)
Continuous blowout.	The valve section of valve (P) (3) leaks.	Disassemble the product. Clean it if the scale is caught. If the parts are defective such as flaws, replace valve (P). (Refer to 6.6.3.)
	Valve (P) (3) does not assembled properly after disassembly.	Assemble the product so that the valve section of valve (P) (3) is inserted to the valve seat. (See Fig. 11.)
Steam leaks to the outside of the product.	The gasket (22) between the body and cover leaks.	Replace gasket (22). (Refer to 6.6.1)
	Strainer gasket (17) leaks.	Replace strainer gasket (17). (Refer to 6.6.7)
	Plug (21) leaks.	Remove plug (21), and replace the seal tape with new one. Reassemble the product.

\* Product disassembly diagram (The parts in the square are consumable parts.)

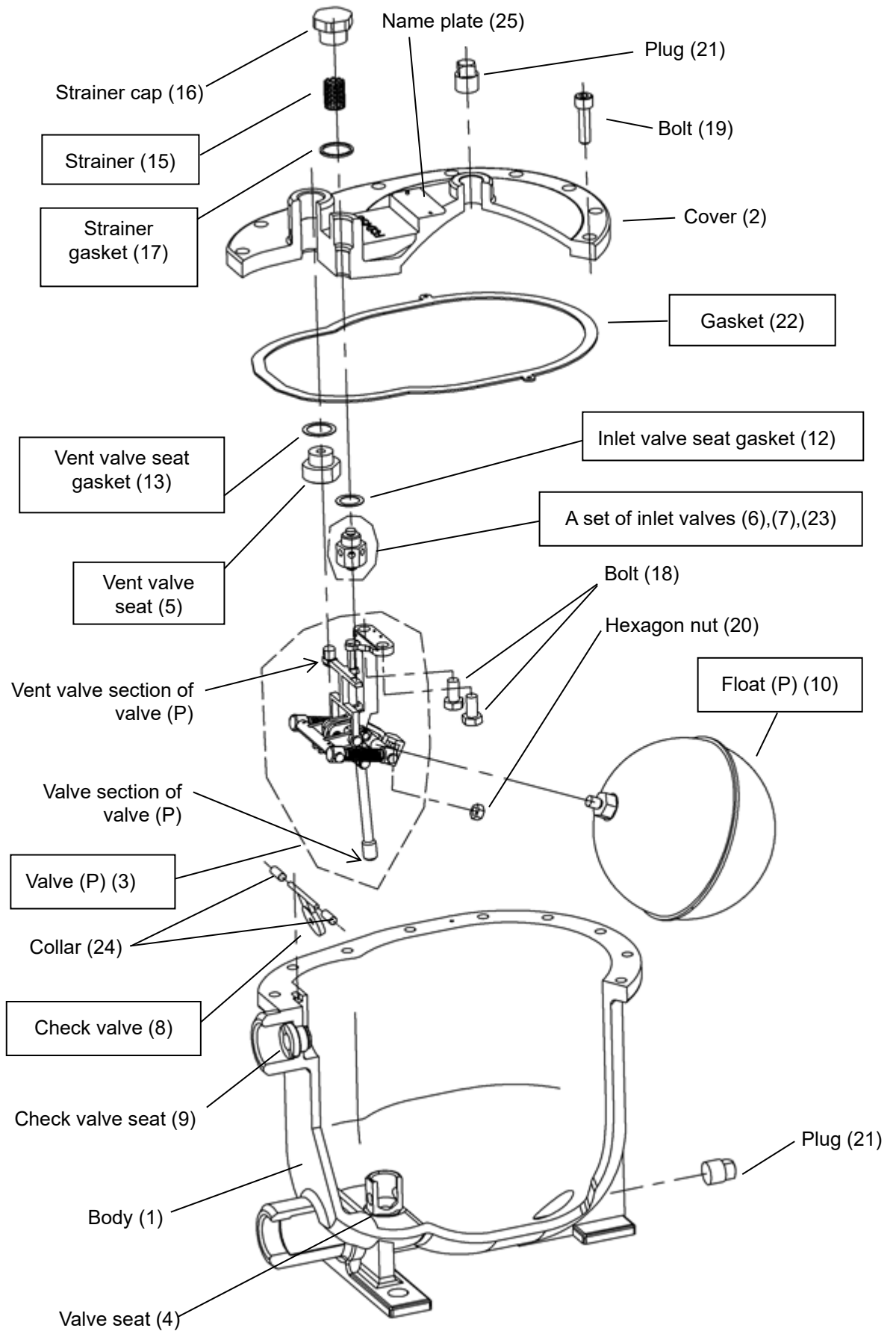

Fig. 10

## 6.5 Disassembly and assembly procedure

### 6.5.1 WARNING and CAUTION during disassembly and assembly

#### WARNING

(1) Before disassembly or inspection, remove internal pressure of the product, pipes, and devices completely and cool down the product. Do not touch the product with bare hands when it is still hot.

\* You might get burned or injured due to remained pressure.

#### CAUTION

(1) Internal condensate flows out during disassembly. Receive it using a container.

\* Without the container, peripheral devices might get dirty.

(2) Check that there are no flaws, dent, or stains on the seat section such as the valve seat. If any stains are found, clean them. If flaws or dent are found, exchange parts.

\* Flaws, dent, or stains might result in malfunction.

(3) Assemble the parts securely. Tighten the bolts evenly in the diagonal order.

\* Improper assembly or uneven tightening of bolts might result in malfunction or leakage.

(4) Use regular parts for repair of products. Never modify the products.

\* If the product is modify, you might get burned or injury due to product damage, steam, condensate, or abnormal operation.

(5) Replace the gasket with a new one.

\* The gasket is a consumable part. If it is reused, leakage might occur.

### 6.5.2 Disassembly procedure (See Fig. 10.)

\* Used tools

Tool name	Contents (Size, nominal, etc.)
Spanner	13 mm, 17 mm, 24 mm
Adjustable end wrench	Width: 0~25 mm
Closed wrench	19 mm, 27 mm
Hexagon socket wrench	Width across flat: 6 mm
Ratchet handle	Used with hexagon socket wrench.

Step 1: Remove strainer cap (16) using a closed wrench (width across flat: 27 mm). Then, the strainer (15) (Cylindrical) and strainer gasket (17) can be removed.

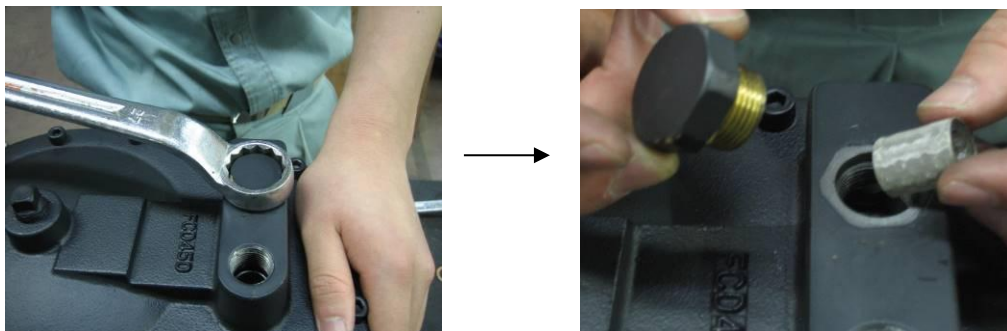

Step 2: Attach the hexagon wrench to the ratchet handle. Remove the bolt (19). Move up the cover and remove the cover (2) and gasket (22) from the body (1).

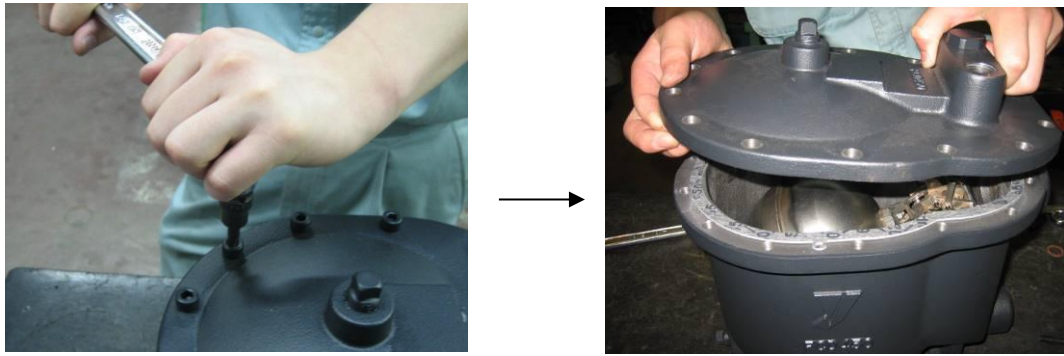

Step 3: Fix the float arm section of valve (P) (3) using the adjustable end wrench. Set the spanner (width across flat 17 mm) at the hexagon section of the float (P), and remove the float (P) (10). The hexagon nut (20) is located at the float arm section. The hexagon nut is necessary for assembly of the float (P).

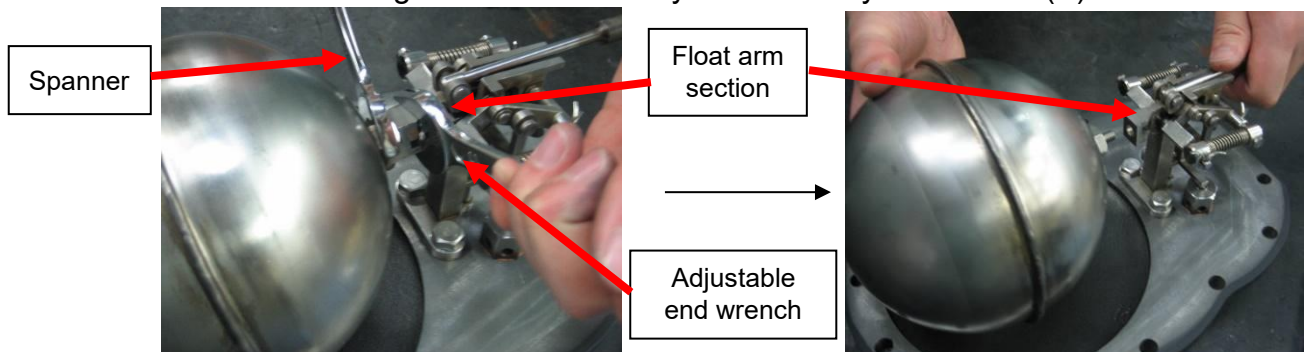

Step 4: Remove two bolts (18) attached to the cover using a spanner (width across flat 13 mm), and remove the valve (P) (3).

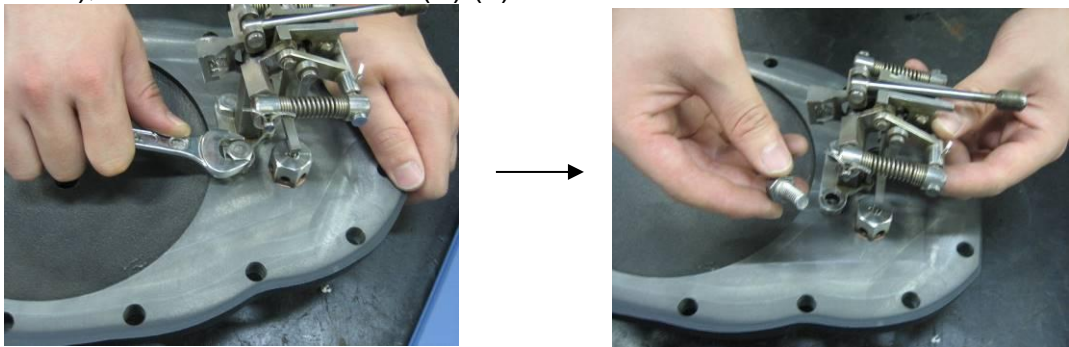

Step 5: Remove a set of inlet valve (6), (7), (23) using the closed wrench (width across flat 19 mm), and remove the inlet valve seat gasket (12).

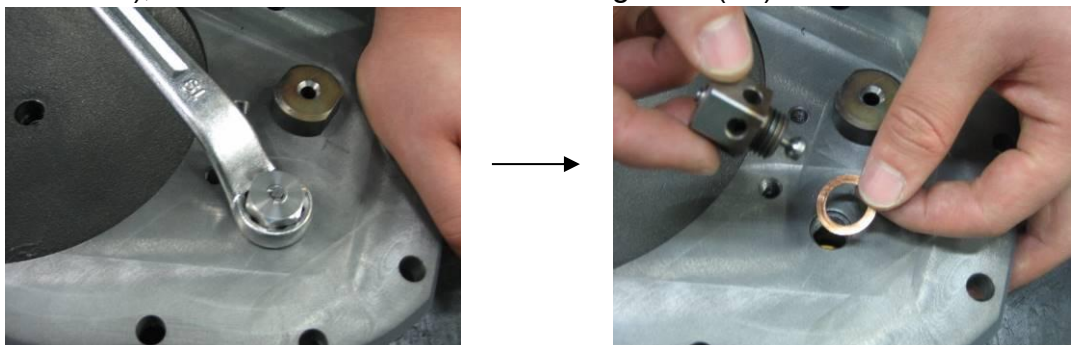

Step 6: Remove the vent valve seat (5) using a spanner (width across flat 24 mm).  
Remove the vent valve seat gasket (13).

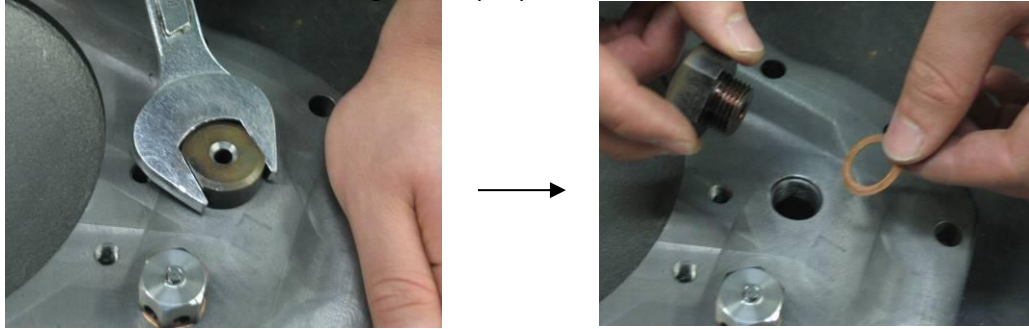

Step 7: Remove the check valve (8) and collar (24) from the body (1) manually.

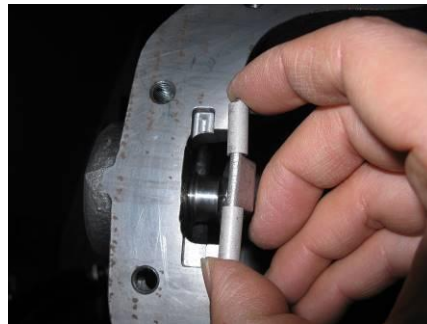

### 6.5.3 Assembly procedure (See Fig. 10.)

\* Used tool

Tool name	Contents (Size, nominal, etc.)
Torque wrench	For items that can be tightened by 35 N·m torque. (using hexagon socket wrench)
Spanner-type torque wrench	Spanner width across flat 17 mm: For items that can be tightened by 15 N·m.
	Spanner width across flat 19 mm: For items that can be tightened by 50 N·m.
	Spanner width across flat 24 mm: For items that can be tightened by 80 N·m.
Spanner	13mm
Closed wrench	27mm
Adjustable end wrench	Width: 0~25 mm
Hexagon socket wrench	Width across flat: 6 mm

Step 1: Install the collar (24) to the check valve (8) and attach check valve to the body (1). Note the installation direction of the check valve. Face the processing surface (with a dent at the center) toward the screw side.

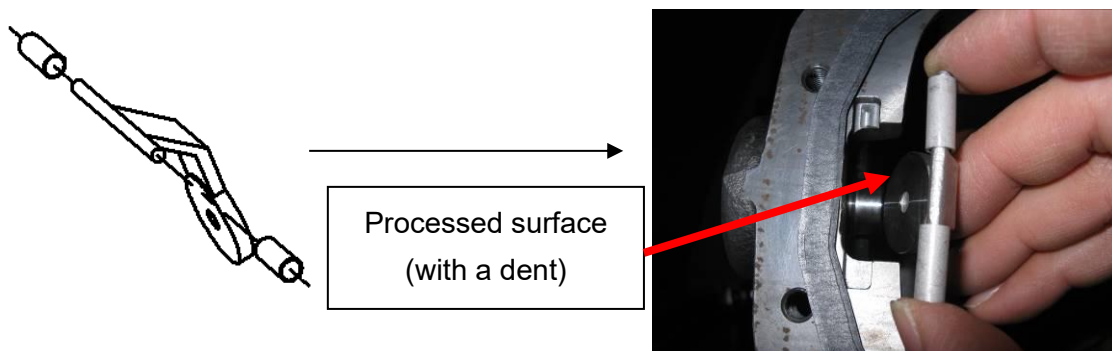

Step 2: Assemble the vent valve seat (5) and vent valve seat gasket (13) to the cover (2). Apply lubricant (machining oil) to the vent valve seat gasket, and assemble it with the vent valve seat. Tighten the vent valve seat with the torque of 80 N·m using the spanner-type torque wrench (width across flat 24 mm).

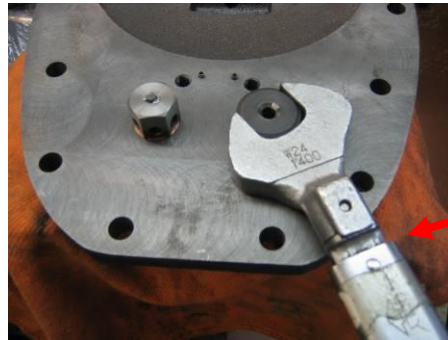

Spanner type torque wrench  
(width across flat 24 mm)

Step 3: Assemble a set of inlet valve (6), (7), (23) and inlet valve seat gasket (12) with the cover (2). Apply lubricant (machining oil) to the inlet valve seat gasket, and assemble it with the inlet valve seat. Tighten the inlet valve seat with the torque of 50 N·m using the spanner-type torque wrench (width across flat 19 mm).

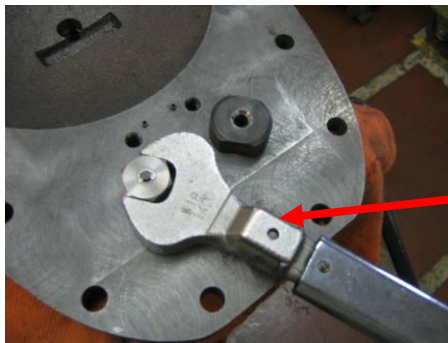

Spanner type torque wrench  
(width across flat 19 mm)

Step 4: To assemble the valve (P) (3) with the cover (2), align the two cover pins with the valve (P). Use two bolts (18) for assembly with the spanner (width across flat 13 mm).

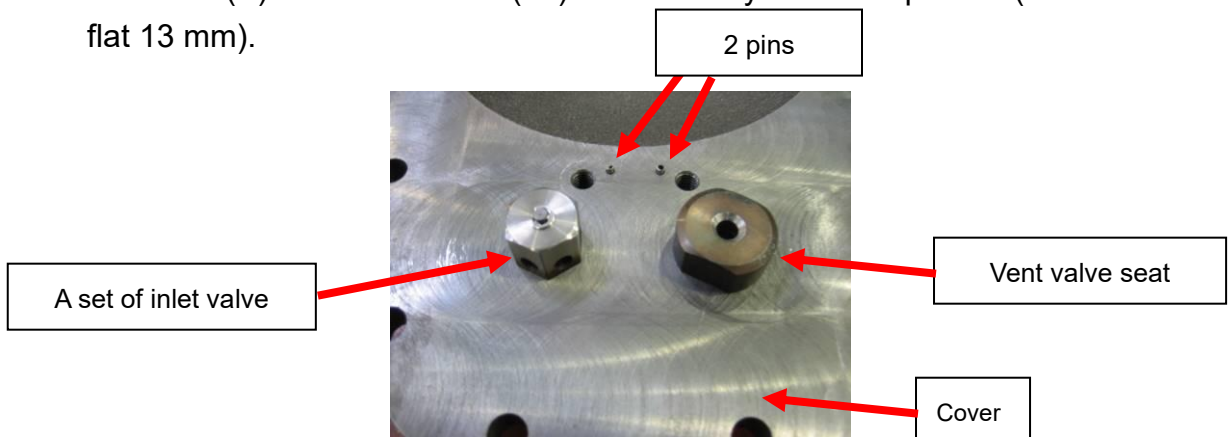

Step 5: Assemble the float (P) (10) with the valve (P)(3). Insert the hexagon nut (20) to the float arm. Fix the float arm using an adjustable end wrench. Tighten the hexagon section (width across flat 17 mm) of the float (P) with the torque of 15 N·m using a spanner-type torque wrench.



Step 6: Replace the gasket (22) with a new one. Before assembling a new one, apply the paste on the entire surface and inside surface of the gasket. (Recommended paste : SOLVEST110 manufactured by STT Co. Ltd.)

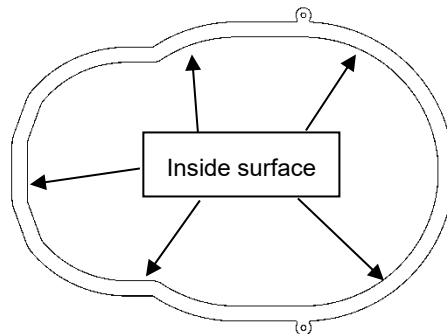

Step 7: Attach the new gasket to the body (1). Confirm that the gasket is completely set to two pins on the body.

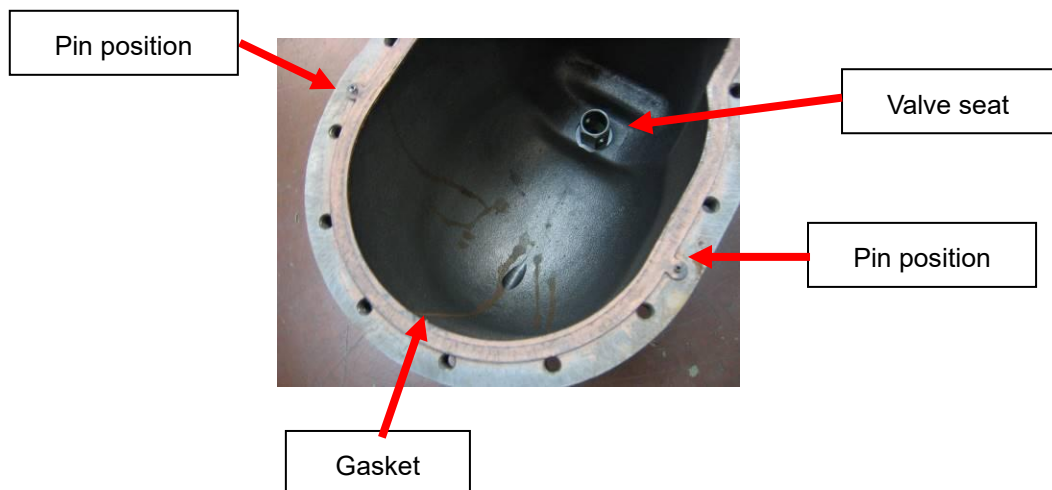

Step 8: Attach the cover (2) to the body (1). Confirm that the valve section of valve (P) (3) is completely inserted to the valve seat inside. (Fig. 11) Attach the cover. Tighten the bolt (19) with the torque of 35 N·m using the torque wrench of the hexagon socket wrench (width across flat 6 mm).

\* Please confirm that the cover (2) attaches to the bolt (2 places) on the body (1) before tighten the bolt (19). Failure to do so may results in broken of the bolt or wrong assembly.

\* Do not use the hexagon L-type wrench for tightening; otherwise, the hexagon hole might be damaged or assembly failures might occur due to insufficient tightening.

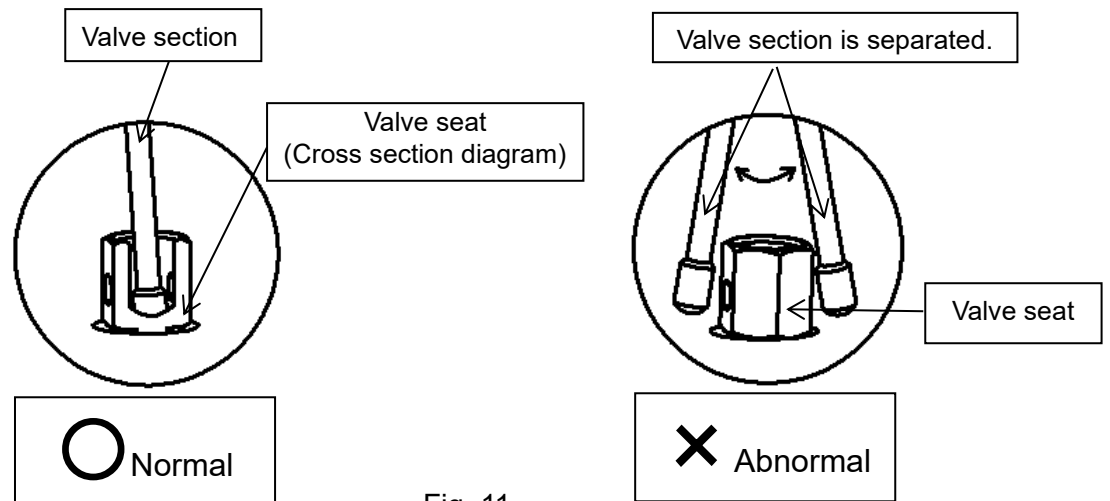
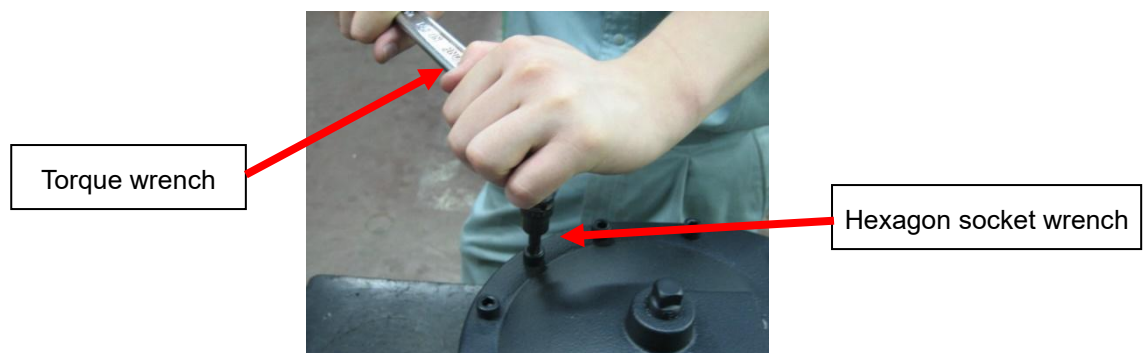

Fig. 11



Step 9: Attach the strainer (15) (cylindrical), strainer gasket (17), and strainer cap (16) to the cover (2). Insert the strainer and strainer gasket to the strainer cap, and screw them into the cover using the closed wrench (width across flat 27 mm).

## 6.6 Replacement procedure of parts

### 6.6.1 Replacement procedure of gasket

Disassemble the gasket in the procedure of step 2 of 6.5.2 Disassembly method. Replace and assemble it in the procedure of steps 6, 7, and 8 of 6.5.3 Assembly procedure.

### 6.6.2 Replacement procedure of float (P)

Disassemble the float in the procedure of steps 2 and 3 of 6.5.2 Disassembly method. Replace and assemble it in the procedure of steps 5, 6, 7, and 8 of 6.5.3 Assembly procedure.

#### 6.6.3 Replacement procedure of valve (P)

Disassemble the valve in the procedure of steps 2, 3, and 4 of 6.5.2 Disassembly procedure. Replace and assemble it in the procedure of steps 4~8 of 6.5.3 Assembly procedure.

#### 6.6.4 Replacement procedure of a set of inlet valve

Disassemble the inlet valve in the procedure of steps 2~5 of 6.5.2 Disassembly procedure. Replace and assemble it in the procedure of steps 3~8 of 6.5.3 Assembly procedure.

#### 6.6.5 Replacement procedure of vent valve seat

Disassemble the vent valve seat in the procedure of steps 2, 3, 4 and 6 of 6.5.2 Disassembly procedure. Replace and assemble it in the procedure of steps 4~8 of 6.5.3 Assembly procedure.

#### 6.6.6 Replacement procedure of check valve

Disassemble the check valve in the procedure of steps 2 ~7 of 6.5.2 Disassembly procedure. Replace and assemble it in the procedure of steps 1, 6~8 of 6.5.3 Assembly procedure.

#### 6.6.7 Replacement procedure of strainer and strainer gasket

Disassemble the strainer and strainer gasket in the procedure of step 1 of 6.5.2 Disassembly procedure. Replace and assemble it in the procedure of step 9 of 6.5.3 Assembly procedure.

### 7. Waste

To dispose (classify and dispose) the product, check the materials of each part, referring to the delivery drawings.

---

## Warranty Information

---

1. Limited warranty

This product has been manufactured using highly-advanced techniques and subjected to strict quality control. Please be sure to use the product in accordance with instructions on the manual and the label attached to it.

Yoshitake warrants the product to be free from any defects in material and workmanship under normal usage for a period of one year from the date of receipt by the original user, but no longer than 24 months from the date of shipment from Yoshitake's factory.

2. Parts supply after product discontinuation

This product may be subject to discontinuation or change for improvement without any prior notice. After the discontinuation of the product, Yoshitake supplies the repair parts for 5 years otherwise individually agreed.

3. This warranty does not cover the damage due to any of below:

- (1) Valve seat leakage or malfunction caused by foreign substances inside piping.
- (2) Improper handling or misuse.
- (3) Improper supply conditions such as abnormal water pressure/quality.
- (4) Water scale or freezing.
- (5) Trouble with power/air supply.
- (6) Any alteration made by other than Yoshitake.
- (7) Use under severe conditions deviating from the design specifications (e.g. in case of corrosion due to outdoor use).
- (8) Fire, flood, earthquake, thunder and other natural disasters.
- (9) Consumable parts such as O-ring, gasket, diaphragm and etc.

Yoshitake is not liable for any damage or loss caused by malfunction or defect of the product.