

MODEL GD-21

Differential Pressure Regulating Valve

PRODUCT MANUAL

Thank you very much for choosing the Yoshitake's product. To ensure the correct and safe use of the product, please read this manual before use. This manual shall be kept with care for future references.

The symbols used in this manual have the following meanings.

	Warning	This symbol indicates a potentially hazardous situation that, if not avoided, could result in death or serious injury.
	Caution	This symbol indicates a hazardous situation that, if not avoided, may result in minor or moderate injury or may result in only property damage.

Table of Contents

1. Specifications	1
2. Operation	2
3. Nominal Size Selection	3
3.1 Nominal sizes selection chart	3
3.2 Calculation formula for Cv value	3
4. Installation	4
4.1 Precautions for installation	4
4.2 Piping example	5
5. Operating Procedure	6
5.1 Precautions for operation	6
5.2 Precautions for air vent	6
5.3 How to use air vent	6
6. Maintenance	6
6.1 Precautions for disassembly and maintenance	6
6.2 Disassembly	7
6.3 Reassembly	7
6.4 Precautions for reassembly	8
7. Troubleshooting	8
8. Exploded Drawing	9
Warranty Information	

YOSHITAKE

1. Specifications

Model		GD-21	
Application		Cold and hot water	
Nominal size		15A-80A	100A-150A
Regulating differential pressure		(A) 0.05-0.25 MPa (B) 0.26-0.7 MPa	(A) 0.05-0.25 MPa (B) 0.26-0.5 MPa
Fluid temperature		5-80°C	
Material	Body	Ductile cast iron	
	Valve seat	Stainless Steel or Bronze	
	Valve disc	NBR	
	Diaphragm	NBR	
Connection		JIS 10K FF Flanged	
Inside surface treatment of body		Electrodeposition coating	

	<p>Caution Please confirm that the indications on the product correspond with the specifications of the ordered model before use. * If they are different, do not use the product and contact us.</p>
---	--

■ Flow rate characteristics chart

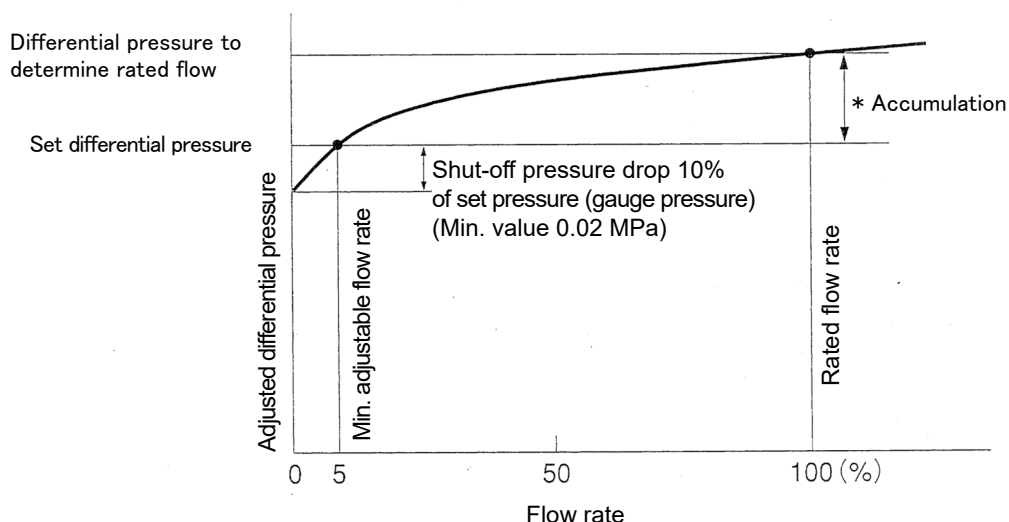

* Accumulation

Set range (MPa)	Accumulation (MPa)
0.05-0.25	0.05 or below
0.26-0.7	0.105 or below

2. Operation

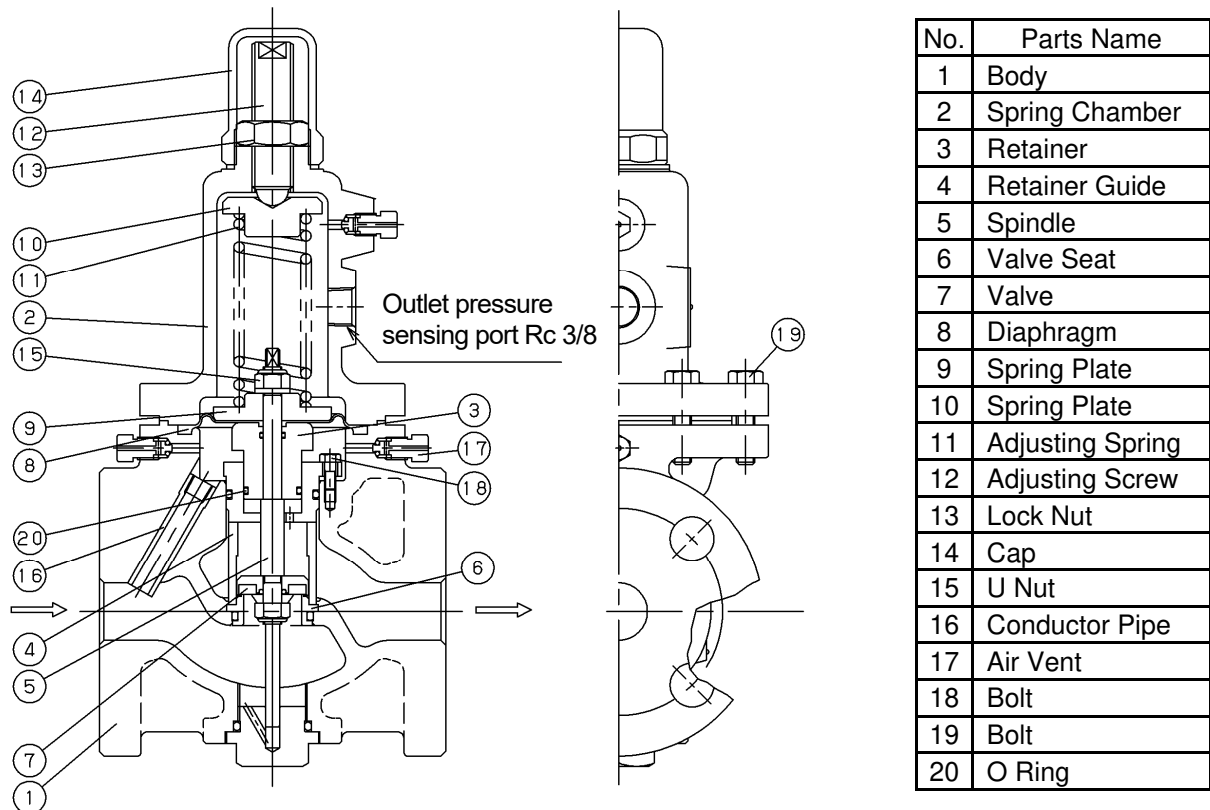

- The shapes differentiate slightly depending on the nominal size.

When fluid flows into the product, the inlet pressure is applied to the bottom side of the diaphragm [8] via the conductor pipe [16] and the outlet pressure is applied to the top side of the diaphragm [8] via outlet pressure sensing port.

The product is kept closed while the pressure difference between before and after the product is less than the set pressure.

When the pressure difference goes over the set pressure, the load of the differential pressure between the top and bottom sides of the diaphragm [8] overcomes the load of the adjusting spring [11] to lift up the valve [7] apart from the valve seat [6], opening the product.

When the pressure difference falls below the set pressure, the product closes again so that the pressure difference between before and after the product can be kept at constant level.

3. Nominal Size Selection

3.1 Nominal size selection chart (For water)

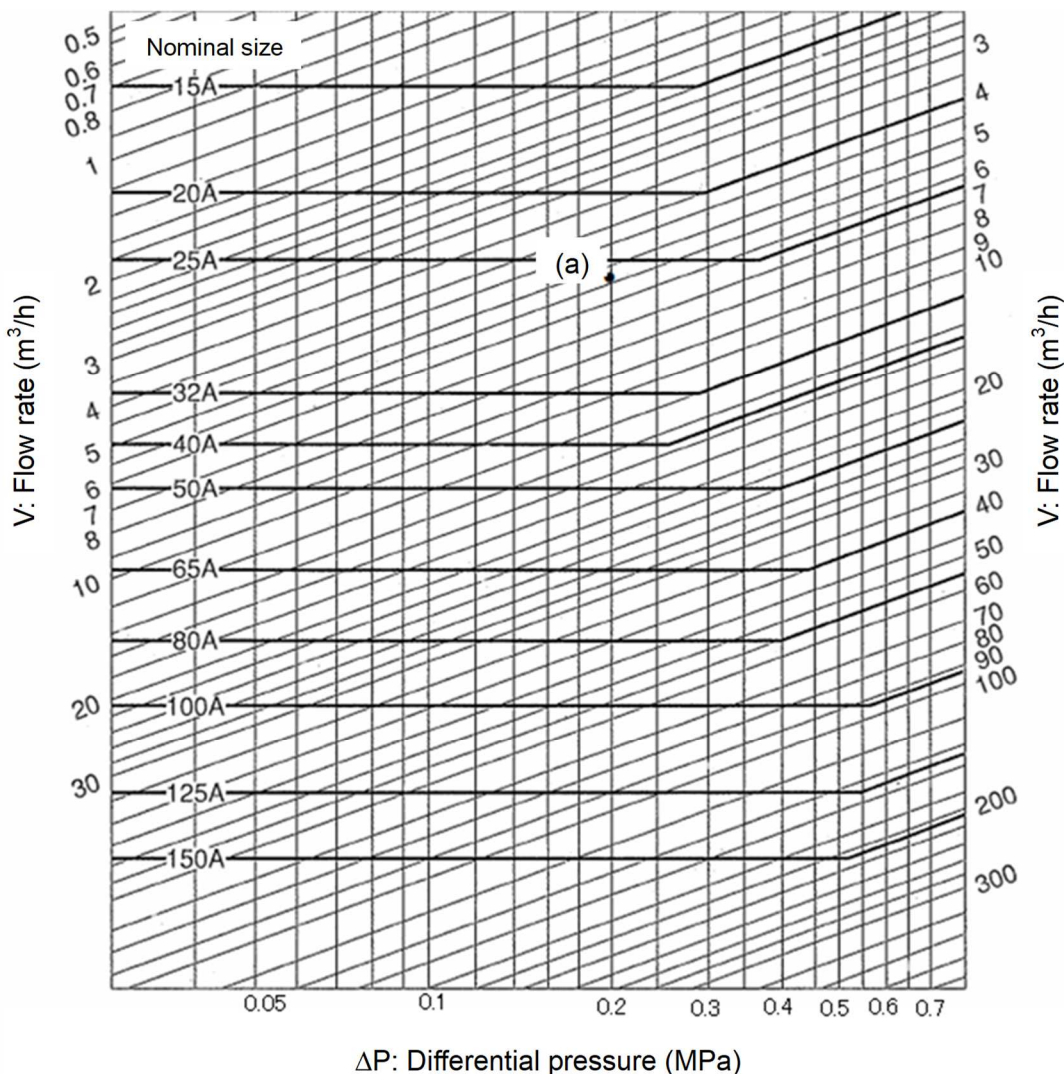

[Example]

When selecting the nominal size of a differential pressure regulating valve with differential pressure (ΔP) of 0.2 MPa and flow rate (V) of 5.5 m³/h, find the intersection point (a) of differential pressure (ΔP) and the flow rate (V).

Since the intersection (a) lies between nominal sizes 25A and 32A, select the larger one, 32A.

3.2 Calculation formula for Cv value

■ Cv value

Nominal size	15A	20A	25A	32A	40A	50A	65A	80A	100A	125A	150A
Cv value	1.5	2.7	4	8.5	11	14	23	32.5	48	75	108

■ Calculation formula for Cv value

$$Cv = \frac{0.365V\sqrt{G}}{\sqrt{\Delta P}}$$

- P₁: Inlet pressure [MPa·A]
- P₂: Outlet pressure [MPa·A]
- ΔP : P₁- P₂ [MPa]
- G : Specific gravity (relative to water)
- V : Max. liquid flow rate [m³/h]
- Cv : Cv value of each nominal size

4. Installation

4.1 Precautions for installation

 Caution	
1.	As the product is heavy, support it securely by lifting device while installation. * Failure to follow this notice may result in bodily injury due to a drop accident.
2.	Do not disassemble the product unless it is necessary. * Disassembly may prevent the product from functioning properly.
3.	Be sure to remove foreign substances and scales from the piping before connecting the product. * Foreign substances and scales may prevent the product from functioning properly.
4.	Install the product vertically to the horizontal piping. If installing it to a vertical piping is inevitable due to limited space, the product can be installed to the vertical piping as long as its size is less than 100A. * Do not install the product of 100A or larger to a vertical piping.
5.	Be sure to install pressure gauges to both the inlet and outlet sides of the product. In addition, install strainer and bypass line to the piping around the product. * Failure to follow this notice may hamper correct pressure adjustment.
6.	Be sure to install a strainer (60-80 mesh) at the inlet side of the product. * Foreign substances or scales may prevent the product from functioning properly.
7.	Quick operating valve shall be installed more than 3 meters away from the product. * Failure to follow this notice may result in malfunction or a drastically shortened service life of the product.
8.	Do not apply excessive load, torque or vibration to the valve when piping. * Failure to follow this notice may result in malfunction or a drastically shortened service life of the product.
9.	Place a drain pipe between the stop valve and the product for easier maintenance and inspections. * Failure to follow this notice may cause fluid spill when disassembling. * Guide the drain pipe to a drain ditch if there is a risk of contamination on the surroundings due to the fluid spill.
10.	Install a needle valve to the outlet side of the product and plumb it to the pressure sensing pipe using copper piping. * Failure to follow this instruction hampers correct pressure adjustment.

- (1) Joint for the outlet pressure sensing is not included with the product package.
- (2) Secure the space specified in the table below (H₂) since it is required for maintenance and inspection. H₂ indicates the required height above the horizontal center line of the piping (see Fig. 1 below).

■ Space required for disassembly (mm)

Nominal size	15A	20A	25A	32A	40A	50A	65A	80A	100A	125A	150A
H ₂	500	500	500	650	650	650	800	800	1000	1200	1400

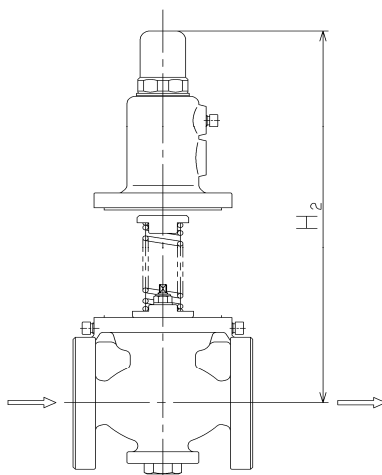

Fig. 1 Space required for disassembly

4.2 Piping example

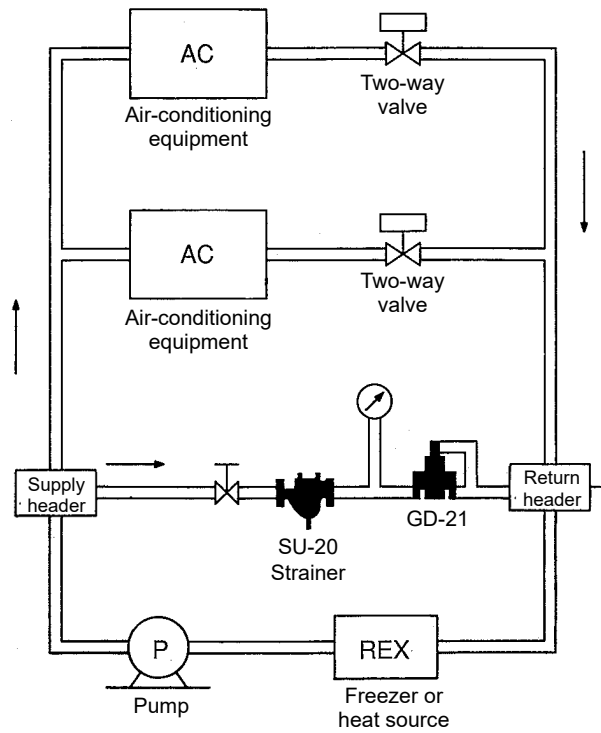
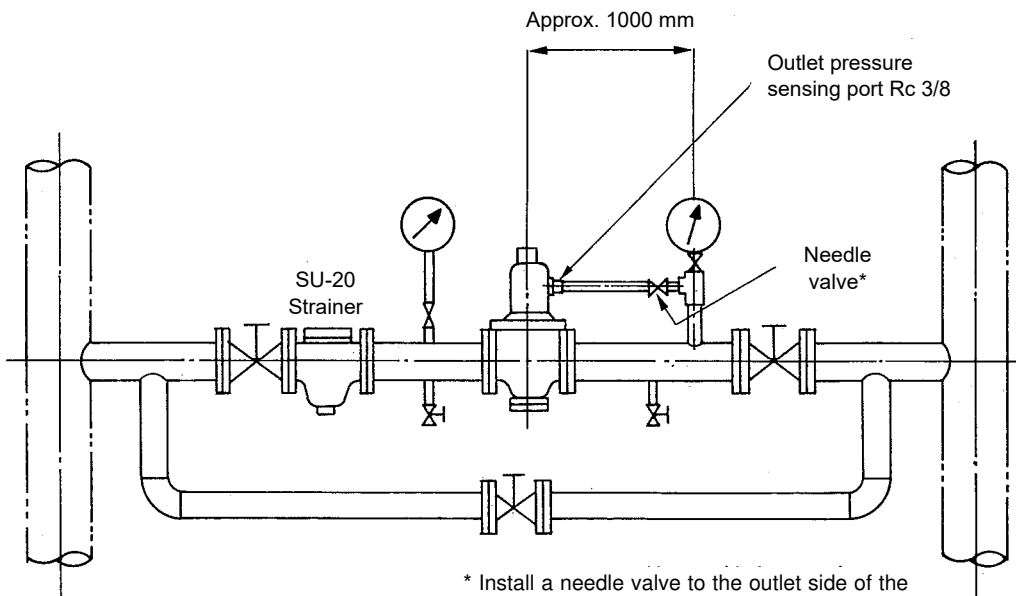

Fig. 2



* Install a needle valve to the outlet side of the product and plumb it to the pressure sensing pipe using copper piping

Fig. 3

5. Operating procedure

5.1 Precautions for operation



Warning

Do not touch the product with bare hands when the fluid has a high-temperature.
* Failure to this notice may scald your skin.



Caution

1. Before leading fluid into the product, close the stop valves before and after the product and remove all foreign substances or scales via the bypass line.
* Foreign substance or scales may prevent the product from functioning properly.
2. Before leaving the product not operated for a long time, discharge the fluid inside of the product and piping completely, and close the stop valves before and after the product.
* Failure to follow this notice may cause malfunction due to rust generated inside the product and piping, or result in damage due to freezing.
* The fluid can be drained out of the product efficiently with the air vent valve (see “8.2 Precaution for air vent”).
3. Pressure regulation of the product shall be performed while the fluid running. To increase the set differential pressure, loosen the lock nut [13], and then slowly turn the adjusting screw [12] clockwise. To decrease the set differential pressure, slowly turn the adjusting screw [12] counterclockwise.
* The fluid leaks if the cap [14] is removed. In this case, use a waste cloth to wipe it out.
4. Remove air accumulated in top and bottom sides of diaphragm using the air vents in accordance with the procedures described in “8.3 How to use air vent.”
* Air accumulated in the top and bottom sides of the diaphragm may cause malfunction of the product.

5.2 Precautions for air vent



Warning

Do not stand in front of the air vent valve during use.
* Failure to follow this notice may result in scalds or bodily injury due to blow-off of the fluid inside.



Caution

Do not rotate the air vents more than 1/2 turn when use.
* Failure to follow this notice may make the air vents detached from the body. In this case, the air vents may not be reattached.

5.3 How to use air vent

- (1) Rotate the screw of the air vent [17] counterclockwise to loosen it order to discharge air.
- (2) Rotate the screw of the air vent [17] clockwise to the original closed position after discharging air.

6. Maintenance

6.1 Precautions for disassembly and maintenance

Warning

1. Disassembling and inspections must be performed by experienced professional or valve manufacturer.
2. Before disassembly or inspection, completely release internal pressure of the product, piping and equipment. When the fluid is hot, cool down the product to the condition that it can be touched with bare hands.
* Residual pressure may cause bodily injury or scalds and may contaminate surroundings of the product.

6.2 Disassembly

- (1) Release the internal pressure from the piping completely, and make sure that the pressure gauge shows that the pressure is zero.
- (2) Remove the cap [14] and slightly loosen the lock nut [13], and then turn the adjusting screw [12] counterclockwise so that the adjusting spring [11] can be in no load condition.
- (3) Remove the spring chamber [2] by unscrewing the bolt [19], and then take out the adjusting spring [11] and the spring plate [10].
- (4) Remove the diaphragm [8] by fixing the spindle [5] and loosening the U nut [15].
- (5) To remove the retainer [3], by loosening the bolt [18] and pulling out the retainer guide [4] together with the retainer [3].

If the retainer guide [4] is difficult to be removed, do as indicated in Fig. 4 or Fig. 5 below

Nominal size 15-50A

To remove the retainer guide [4] easily, reattach the spring plate [9] and U nut [15] to the spindle [5], then pull up the spring plate [9].

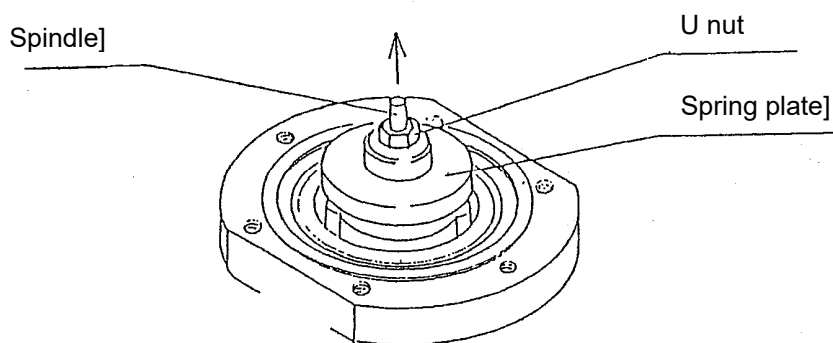

Fig. 4

Nominal size 65-150A

To remove the retainer guide [4] easily, screw the bolt [18] to the retainer guide [4] and pull them out. (See Fig. 5)

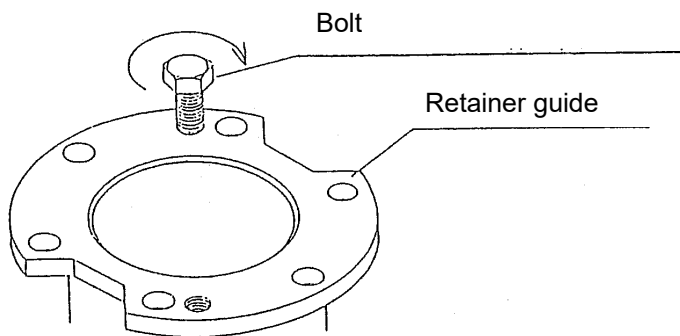



Fig. 5

6.3 Reassembly

To reassemble the product, take reverse procedure to disassembly.

6.4 Precautions for reassembly

 Caution
<p>1. Make sure that there are no flaws on the diaphragm [8], the valve seat [6] and the valve [7]. * Flaws on them may prevent the product from functioning properly.</p> <p>2. Apply silicon grease to the O-ring [20] after confirming that there are no flaws on it. * Without silicon grease, the O-ring may be torn.</p> <p>3. Confirm that the lip of the diaphragm [8] is fitted in the grooves on the body [1], and then attach the spring chamber [2]. * Failure to follow this notice may prevent the product from functioning properly.</p> <p>4. There should be a gap between the retainer guide [4] and the body [1] when properly assembled. Tighten the bolts evenly to avoid over-tightening them.</p>

7. Troubleshooting

Trouble	Cause	Remedy
Excessive leakage Adjustment is impossible.	1. Foreign substances stuck between valve [7] and valve seat [6]. Or damage on valve [7] and/or valve seat [6].	1. Disassemble and clean, or replace.
	2. Damage on diaphragm [8] and/or O-ring.	2. Replace diaphragm [8] and/or O-ring [20].
	3. Nominal size is too small for the specifications.	3. Replace the product to obtain proper nominal size (see "6.1 Nominal size selection chart").
	4. Pressure gauge is out of order.	4. Replace.
Abnormal sound is observed	1. Air-induced problem occurs.	1. Install exhaust equipment.
	2. Nominal size is too large for the specifications.	2. Replace the product to obtain proper nominal size (see "6.1 Nominal size selection chart").

8. Exploded Drawing

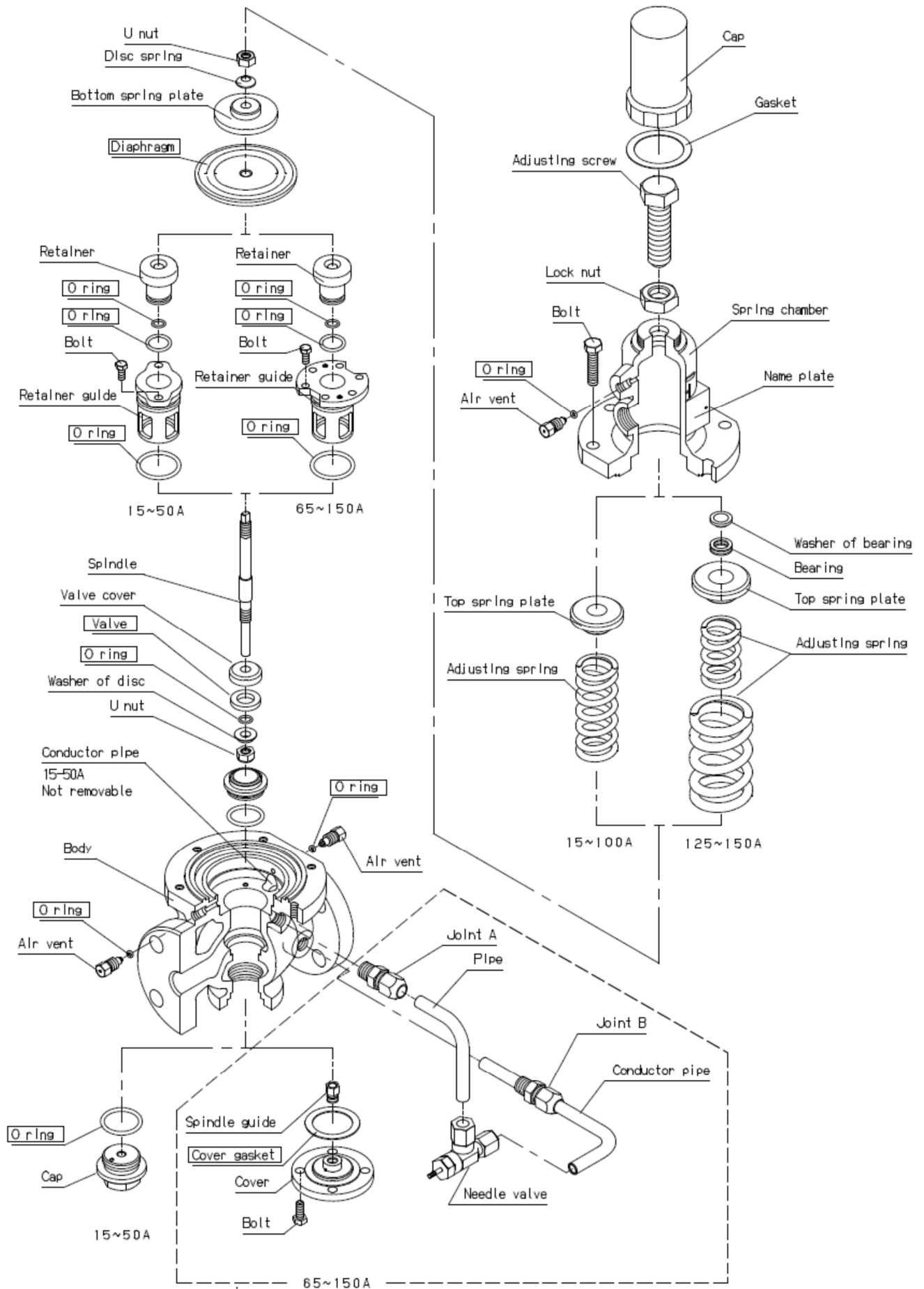

The parts name shown in the rectangle boxes are available as consumable supply.

Warranty Information

1. Limited warranty

This product has been manufactured using highly-advanced techniques and subjected to strict quality control. Please be sure to use the product in accordance with instructions on the manual and the label attached to it.

Yoshitake warrants the product to be free from any defects in material and workmanship under normal usage for a period of one year from the date of receipt by the original user, but no longer than 24 months from the date of shipment from Yoshitake's factory.

2. Parts supply after product discontinuation

This product may be subject to discontinuation or change for improvement without any prior notice. After the discontinuation of the product, Yoshitake supplies the repair parts for 5 years otherwise individually agreed.

3. This warranty does not cover the damage due to any of below:

- (1) Valve seat leakage or malfunction caused by foreign substances inside piping.
- (2) Improper handling or misuse.
- (3) Improper supply conditions such as abnormal water pressure/quality.
- (4) Water scale or freezing.
- (5) Trouble with power/air supply.
- (6) Any alteration made by other than Yoshitake.
- (7) Use under severe conditions deviating from the design specifications (e.g. in case of corrosion due to outdoor use).
- (8) Fire, flood, earthquake, thunder and other natural disasters.
- (9) Consumable parts such as O-ring, gasket, diaphragm and etc.

Yoshitake is not liable for any damage or loss caused by malfunction or defect of the product.