

TRAP STAR™ MODEL TSF-8AT, 11AT **AIR TRAP**

Thank you very much for choosing the Yoshitake's product. To ensure the correct and safe use of the product, please read this manual before use. This manual shall be kept with care for future references. The symbols used in this manual have the following meanings.



	Warning	This symbol indicates a potentially hazardous situation that, if not avoided, could result in death or serious injury.
	Caution	This symbol indicates a hazardous situation that, if not avoided, may result in minor or moderate injury or may result in only property damage.

Table of Contents

1. Specifications	1
2. Operation	2
3. Maximum Continuous Discharge Capacity	3
4. Installation	
4.1 Piping example	4
4.2 Precaution for installation	6
5. Operating Procedure	
5.1 Precaution for operating procedure	8
6. Maintenance	
6.1 Precaution for maintenance	9
6.2 Daily and periodic inspections	10
6.3 Troubleshooting	11
6.4 Exploded drawing	12
6.5 Disassembly	13
6.6 Reassembly	13
Warranty Information	

YOSHITAKE

1. Specifications

Model	TSF-8AT	TSF-11AT
Nominal size	15A-25A	32-50A
Application	Air, Other non-dangerous fluid	
Working pressure (Maximum working differential pressure)	TSF-□AT-5: 0.01-0.5 MPa (0.5 MPa) TSF-□AT-10: 0.01-1.0 MPa (1.0 MPa) TSF-□AT-21: 0.01-2.1 MPa (2.1 MPa)	
Max. temperature	220°C	
Material	Body	Ductile cast iron
	Float	Stainless steel
	Valve, valve seat	Stainless steel
Connection	JIS Rc screwed NPT screwed	
Flow direction	Horizontal installation*	

* TSF-8AT: Standard products have a left-to-right flow direction. For right-to-left flow, the suffix "R" is added.
 TSF-11AT: The flow direction when shipping is adjusted from left to right. When using from right to left, see No.7, "4.2 Precaution for installation" on page 6.

* For installation posture, see No.6, "4.2 Precaution for installation" on page 6.

 <p>Caution</p>	<p>1. Depending on application, specification of the product shall be selected. Refer to Technical material, e.g. Product manual, Technical guidebook, and drawing, and select suitable specification. Regarding technical material like drawing, contact our sales office.</p> <p>2. Please confirm that the indications on the product correspond with the specifications of the ordered product model before use. * If they are different, do not use the product and contact us.</p>
---	---

2. Operation

- (1) Right after the installation, the product contains gas and the float (P) ④ is lowered by its own weight, so the valve ⑦ is closed.
- (2) When condensate comes into the product, the float lifts up by buoyancy, floats up and the valve ⑦ opens to discharge condensate.
- (3) When condensate is discharged, the condensate level falls and the float's buoyancy to the float decreases, and the valve ⑦ closes.
- (4) Condensate can be discharged by repeating the operation of (2) and (3) thereafter.

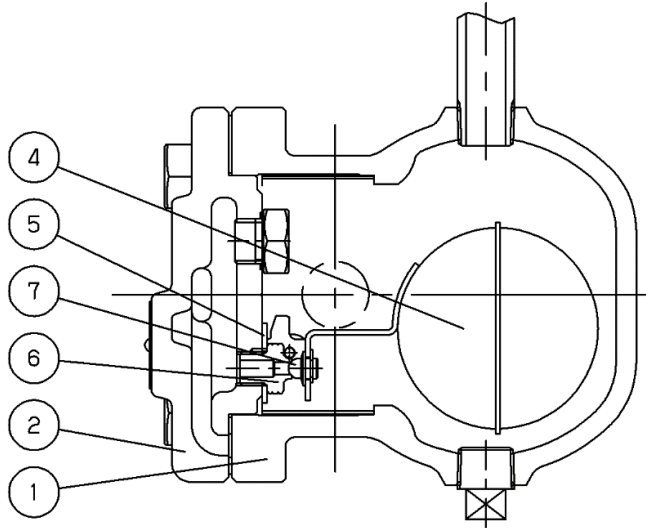

⑦	Valve
⑥	Valve seat
⑤	Float holder
④	Float(P)
②	Cover
①	Body
No	Parts name

3. Maximum Continuous Discharge Capacity

1. Discharging capability of the air trap differs by working differential pressure, that is, difference between inlet pressure and outlet pressure (back pressure). In selecting discharge capacity, consider outlet pressure. If inlet pressure is 0.5 MPa and outlet pressure is 0.2 MPa, discharge capacity is of working differential pressure of 0.3 MPa.
2. The discharge capacity shown in the charts below is the maximum value. In designing a system, select an air trap with a sufficient safety factor (two times the regular level). That is, for example, if a discharge capacity of 100 kg/h is required, select a steam trap capable of discharging more than 200 kg/h (maximum discharge).

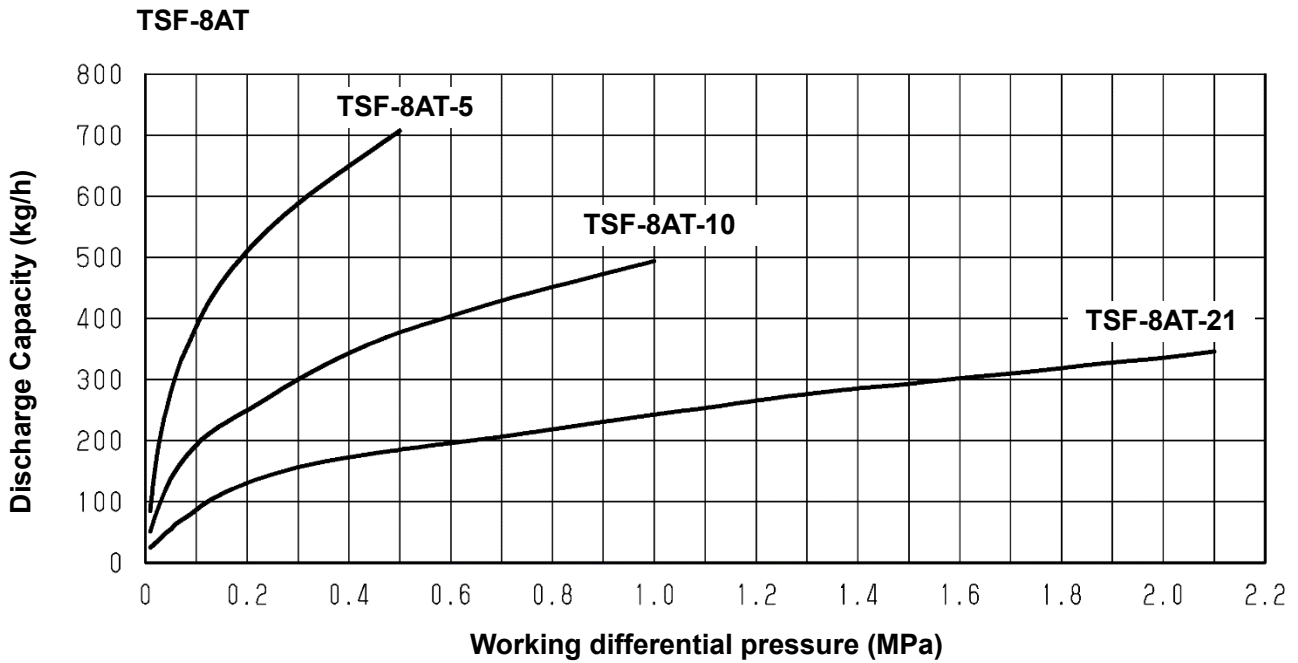

Maximum Continuous Discharge Capacity Chart

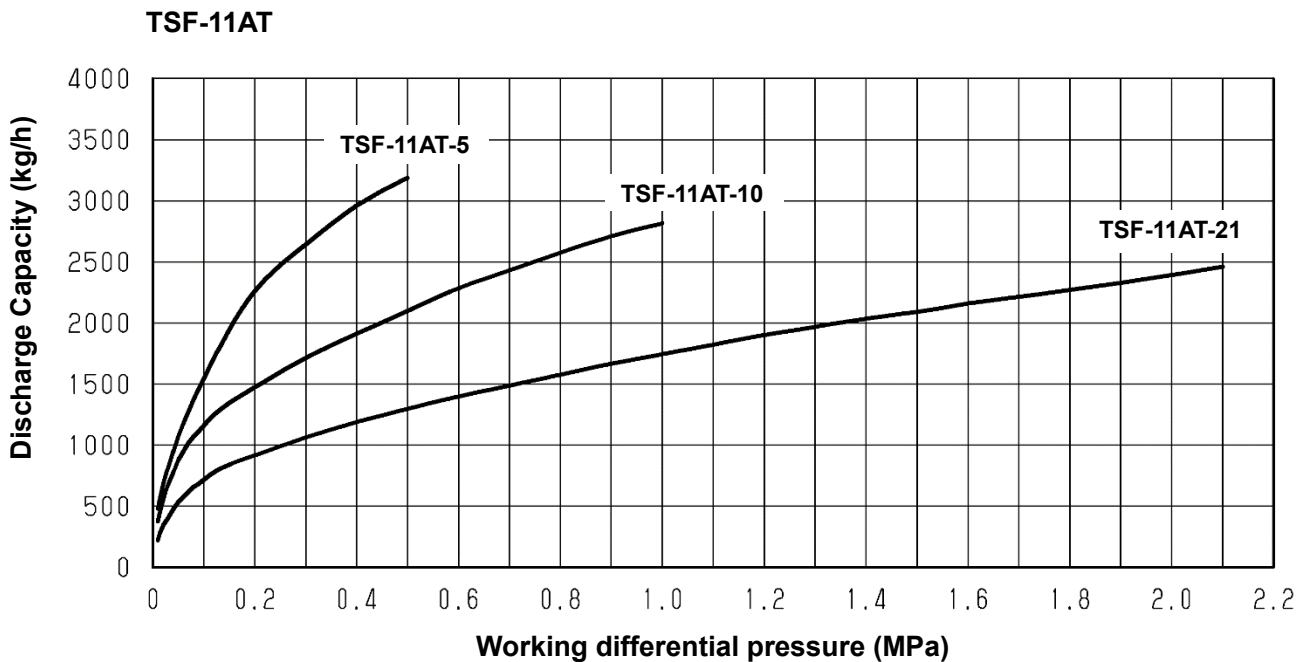

4. Installation

4.1 Piping example

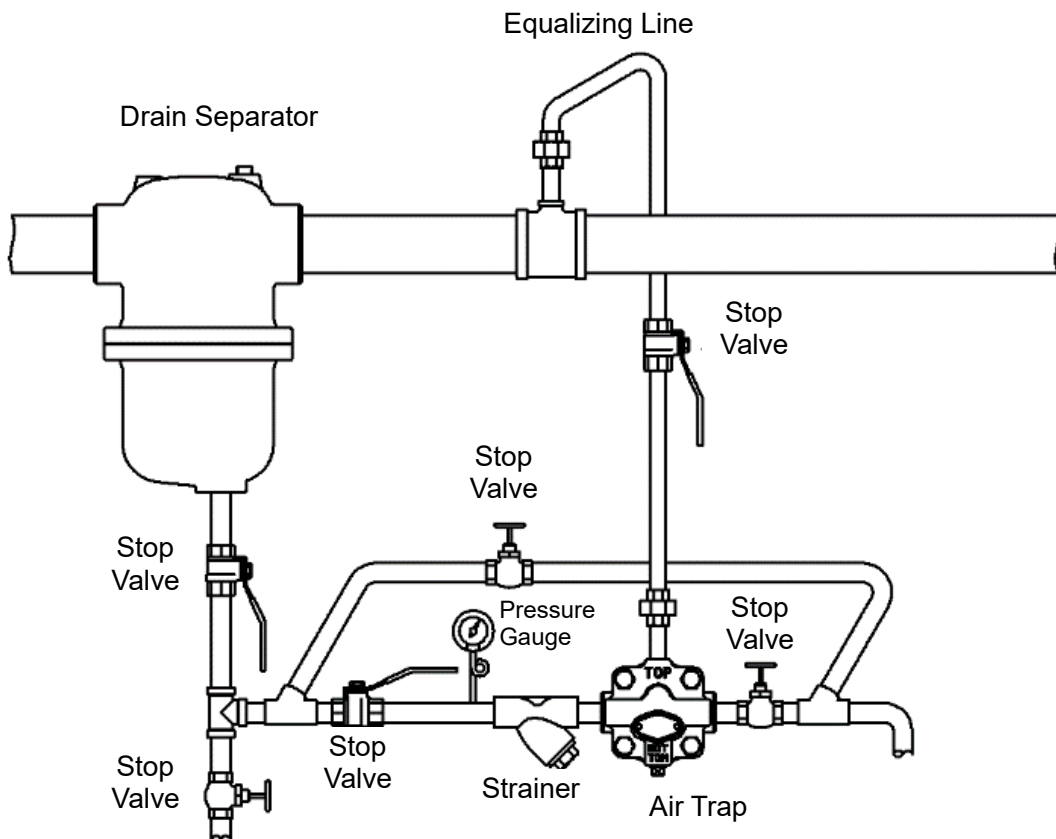
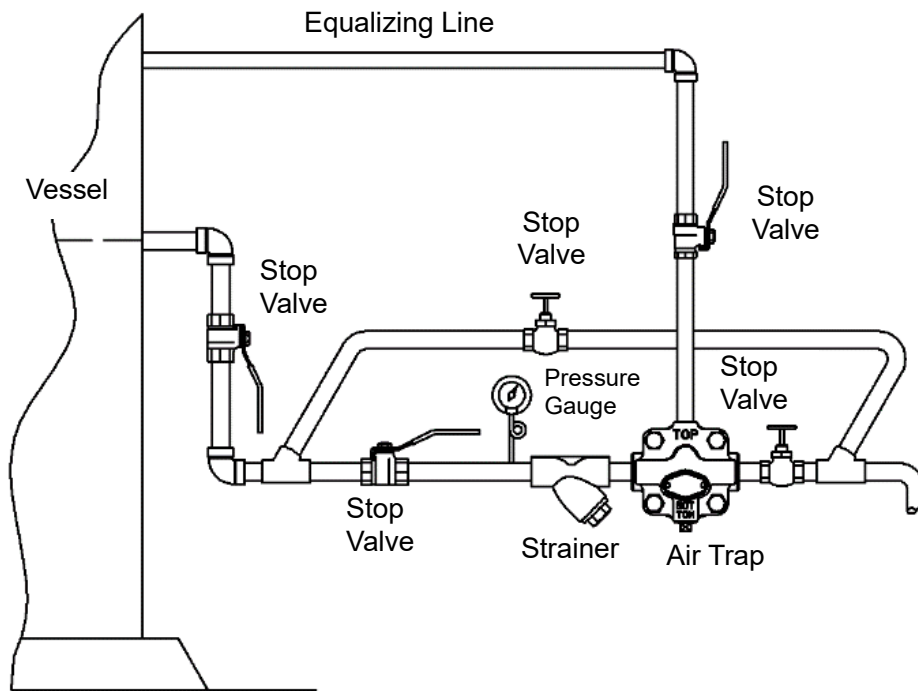

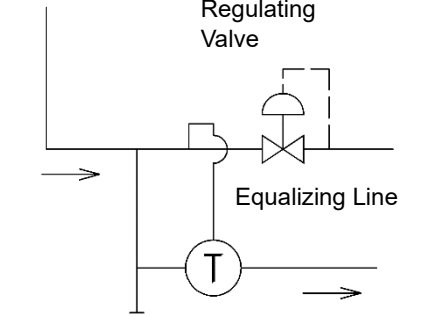
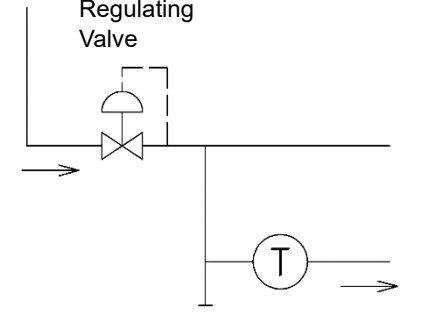
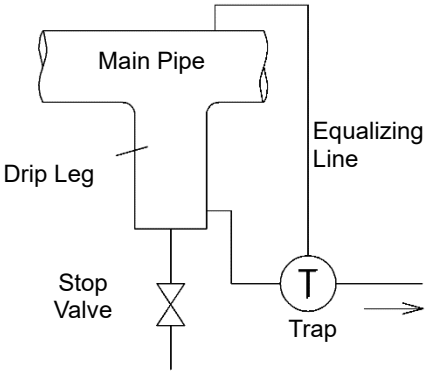
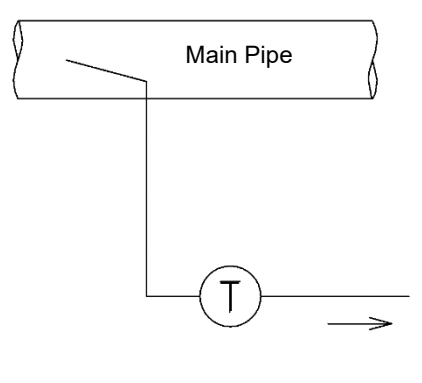
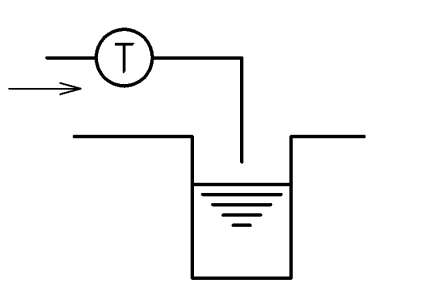
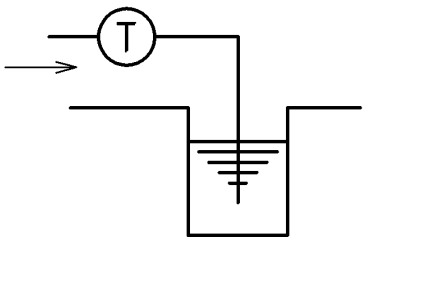
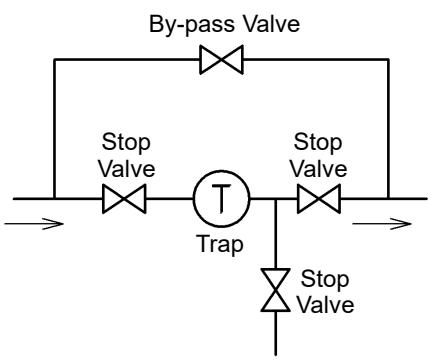
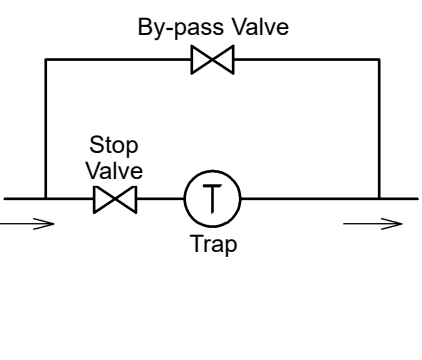
Description	Correct	Incorrect
<p>If the product is installed close to a regulating valve, make sure to install the product at the inlet side of the regulating valve.</p>	 <p>Regulating Valve</p> <p>Equalizing Line</p>	 <p>Regulating Valve</p>
<p>To discharge condensate from the main pipe, be sure to install the product so that condensate can be discharged from the bottom of the main pipe by drip leg.</p>	 <p>Main Pipe</p> <p>Drip Leg</p> <p>Stop Valve</p> <p>Equalizing Line</p> <p>Trap</p>	 <p>Main Pipe</p>
<p>End portion of discharge pipe shall be off the water surface in the pit.</p>		
<p>Provide a by-pass line around the product, and install stop valves at the outlet side of the product.</p>	 <p>By-pass Valve</p> <p>Stop Valve</p> <p>Trap</p> <p>Stop Valve</p> <p>Stop Valve</p>	 <p>By-pass Valve</p> <p>Stop Valve</p> <p>Trap</p>

4.2 Precaution for installation

⚠ Caution

1. Before connecting the product to piping, remove foreign substances and scale from the piping.
* Failure to follow this notice may prevent the product from functioning properly.
2. Protective covers are attached to the inlet and outlet connections of some products to prevent foreign matter from entering the product. Please remove them before installation.
3. To install the product, check the direction of the product so that the fluid flowing and the arrow marked on the product are in the same direction.
* Setting the product in wrong directions prevents it from functioning properly.
4. When installing the product in piping, be careful not to allow sealant or sealing tape to enter the product.
5. Do not apply excessive load, torque or vibration to the valve.

6. Check installation posture.

- * Wrong posture hampers proper operation.

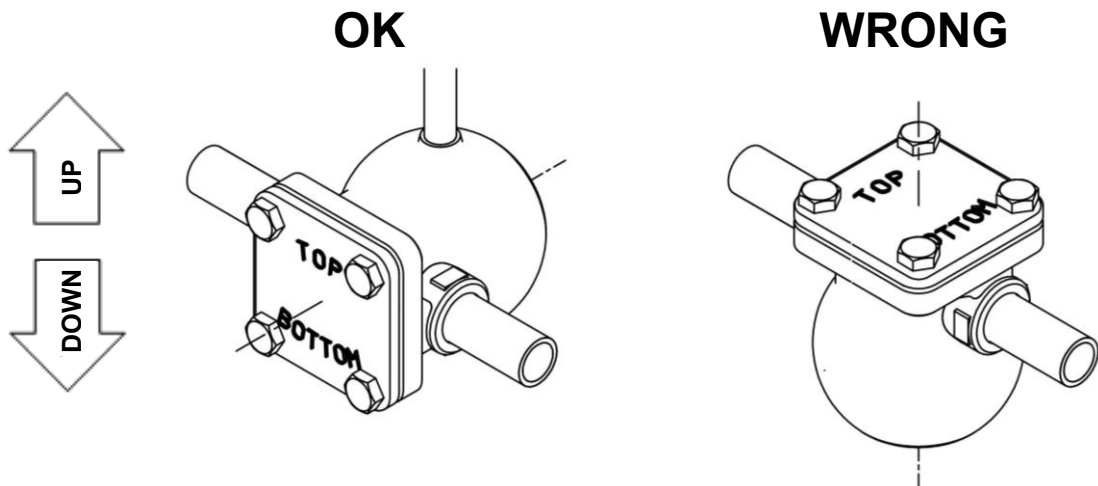

- * Allowable tilt from horizontal line is within $\pm 10^\circ$.

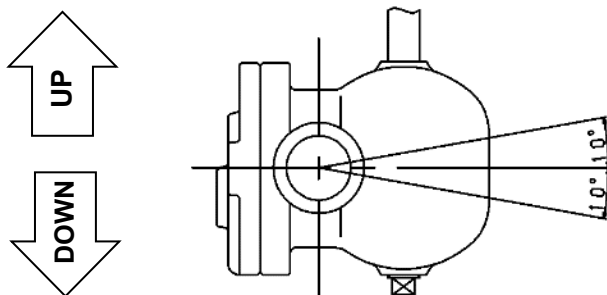

7. TSF-11AT: Adjust direction of the name plate in no pressure condition after installation.

- * Do not turn the cock unless the pressure inside of the product and piping is completely discharged. Forcing the cock to turn may result in damage to the cock.
- * Wrong direction hampers proper operation.

* Fix the cock with spanner and loosen the nut. Turn the cock and adjust direction of the name plate to position "TOP" and "BOTTOM" signs on upside and downside respectively.

* Fix the cock with spanner and fasten the nut after adjustment.

- * Allowable tilt from vertical line is within $\pm 10^\circ$.

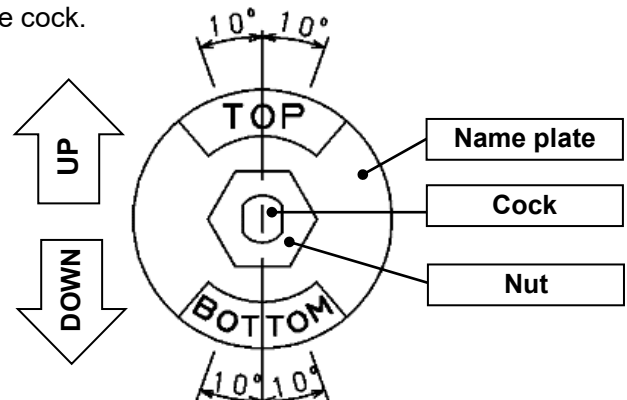

8. Make sure to support the piping immovably.
 - * If an excessive piping stress is applied, the product may not open or close.
9. Do not disassemble the product unless it is necessary.
 - * Disassembly may prevent the product from functioning properly.
10. Secure enough space for maintenance (such as cleaning of strainer), inspections and repair as shown below.
 - * Failure to follow this notice prevents maintenance, inspection and repair.

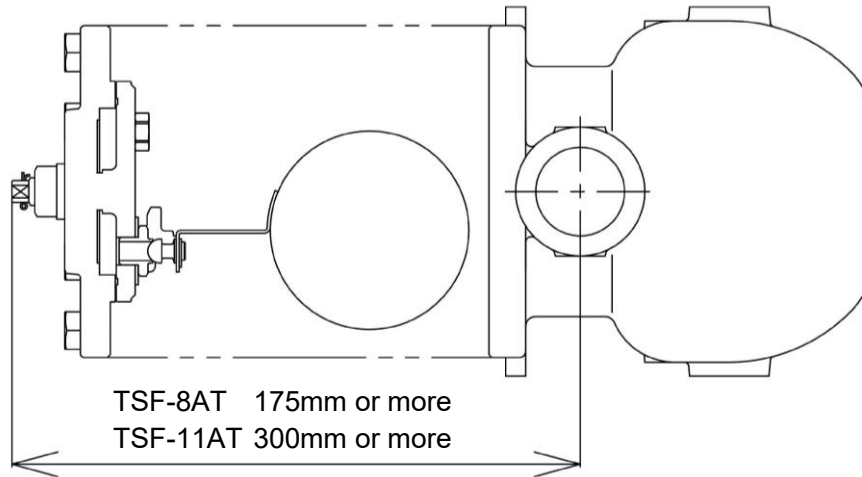

11. Slope the piping and place the product at as a low position as possible in order to make condensate flow into the product by its own weight.
12. To install the product in a main pipe, provide a drip leg at the inlet side of the product.
13. Install a strainer (mesh size of 80 or more is recommended) at the inlet side of the product.
14. Install the product so that it is not subjected to the shock of water hammer. Do not install a quick operating valve before and/or after the product.
 - * Failure to follow this notice may result in malfunction due to damage to the float, or may result in scalds or injury due to blow off when the product is subjected to an excessive shock and damaged.
15. Install a bypass line.
 - * The system has to stop operation while inspection and maintenance of the product if the bypass line is not installed.
16. Be sure to install an equalizing line to prevent condensate accumulation.
 - * Install an equalizing line above the condensate level in the product.
17. If there is a possibility of freezing, take proper measures to remove water inside of the product and piping, and insulate the product.

5. Operating Procedure

5.1 Precaution for operating procedure



Warning

1. Before leading fluid, make sure that the product is securely connected to piping and that there is no loose.
 - * Failure to follow this notice may result in scalds or injury due to blow-off.
2. Do not touch the product with bare hands while the product operates when using high temperature fluid.
 - * Failure to follow this notice may result in scalds.
3. Do not stand in front of the outlet opening of the product while the product operates.
 - * Failure to follow this notice may result in scalds or injury due to blow-off.



Caution

1. Slowly open each stop valve to prevent water hammer.
 - * Opening stop valves quickly may result in damage to other equipments due to hunting or water hammer.
2. Do not turn the cock while the product operates.
 - * Do not turn the cock unless the pressure inside of the product and piping is completely discharged. Forcing the cock to turn may result in damage to the cock.
 - * Wrong direction of the cock hampers proper operation.
3. When the operation is stopped for a long period of time, drain the condensate from the product and piping.
 - * Failure to follow this notice may cause malfunction due to rust inside of the product and piping, or damage due to freezing.

6. Maintenance

6.1 Precaution for maintenance



Warning

1. Disassembly and inspections must be performed by a professional or the manufacturer.
2. When using high temperature fluid, do not touch the product with bare hands.
* Failure to follow this notice may result in burns.
3. Be sure to completely release the internal pressure of the product, piping, and equipment when disassembling and maintenance. In the case of high temperature fluid, please cool the product body until it touches with bare hands.
* Failure to follow this notice may result in scalds or injury due to residual pressure.



Caution

1. Conduct daily inspection in order to maintain the optimal performance of the product.
* Failure to follow this notice may prevent the product from functioning properly.
* See "6.3 Troubleshooting" on page 11 if trouble is observed.
2. After leaving the product not operated for a long period, perform inspection before start-up of operation.
* Failure to follow this notice may cause malfunction due to rust inside of the product and piping.
3. Put a container under the product at disassembly since condensate may flow out.
* Failure to follow this notice may result in making the surroundings dirty.
4. Be careful not to drop the parts at the time of disassembly. The disassembled parts should be placed on soft cloth in order to avoid scratches and damage.
* Damage on the parts may cause malfunction and affect the optimal performance.
5. To assemble, connect all the parts securely and tighten the bolts uniformly in diagonal order.
* Failure to follow this notice may cause malfunction or outside leakage.
6. When repairing, do not use the parts other than the dedicated parts manufactured by Yoshitake. Do not modify the product.
* Failure to follow this notice may cause damage to the product, or may result in scalds or injury due to blow-off or malfunction.
7. In case of problems due to foreign substances or scale, the product needs repair or part replacement. Please contact us for details.
(Please note that any repair due to foreign substances or scale in the product is subject to a charge even during the warranty period.)

6.2 Daily and periodic inspections

Conduct daily and periodic inspections in order to maintain the optimal performance of the product. See "6.3 Troubleshooting" on Page 10 for the remedies if trouble is observed.

- Daily inspection (once a day)

Conduct daily inspection during operation of the product.

Items	Standards for Inspection
Discharge condition of condensate	Condensate is discharged smoothly.
Outside leakage	No outside leakage of condensate or fluid.

- Periodic inspection (once a year)

Conduct disassembly inspection periodically.

Items	Standards for Inspection
Seating surfaces of the valve and valve seat	No scratch, abrasion, or foreign substances on seating surfaces.
Shape of float (P)	No deformation or damage on the float (P)
Dirt on the screen	No clogging on the screen

6.3 Troubleshooting

Trouble	Cause	Remedy
Condensate is not discharged.	1. Blockage of foreign substances in a discharge hole of the valve seat.	1. Disassemble and clean it.
	2. The screen is clogging.	2. Disassemble and clean it.
	3. The float (P) is damaged.	3. Replace it with a new one.
	4. Breakage as a result of abnormal pressure rising due to freezing or water hammer, etc.	4. Replace the product with new one and use it within the working pressure range.
	5. Condensate accumulation has occurred in the equalizing line.	5. Please review the layout of the equalizing line to prevent the occurrence of condensate accumulation.
	6. "TOP" and "BOTTOM" signs on the name plate are in wrong positions.	6. Adjust direction of the name plate to position "TOP" and "BOTTOM" signs on upside and downside respectively. * See Caution No. 6, "4.2 Precaution for installation" on page 6.
Continuous blowout.	1. Foreign substances stuck on valve or valve seat.	1. Disassemble and clean them.
	2. Abrasion or scratches on the valve or valve seat.	2. Replace the parts with new ones.
	3. Insufficient capacity of the product.	3. Replace the product with another model of sufficient capacity.
	4. "TOP" and "BOTTOM" signs on the name plate are in wrong positions.	4. Adjust direction of the name plate to position "TOP" and "BOTTOM" signs on upside and downside respectively. * See Caution No. 6, "4.2 Precaution for installation" on Page 6.
Outside leakage.	1. Leakage due to loosening of the bolt.	1. Replace the cover gasket with new one, and retighten the bolt.
	2. Leakage as a result of abnormal pressure rising due to freezing or water hammer, etc.	2. Replace the product with new one and use it within the working pressure range.

6.4 Exploded drawing

The parts shown in the rectangle boxes are available as consumable supply.

*Remove the plug on the "TOP" side and install an equalizing line.

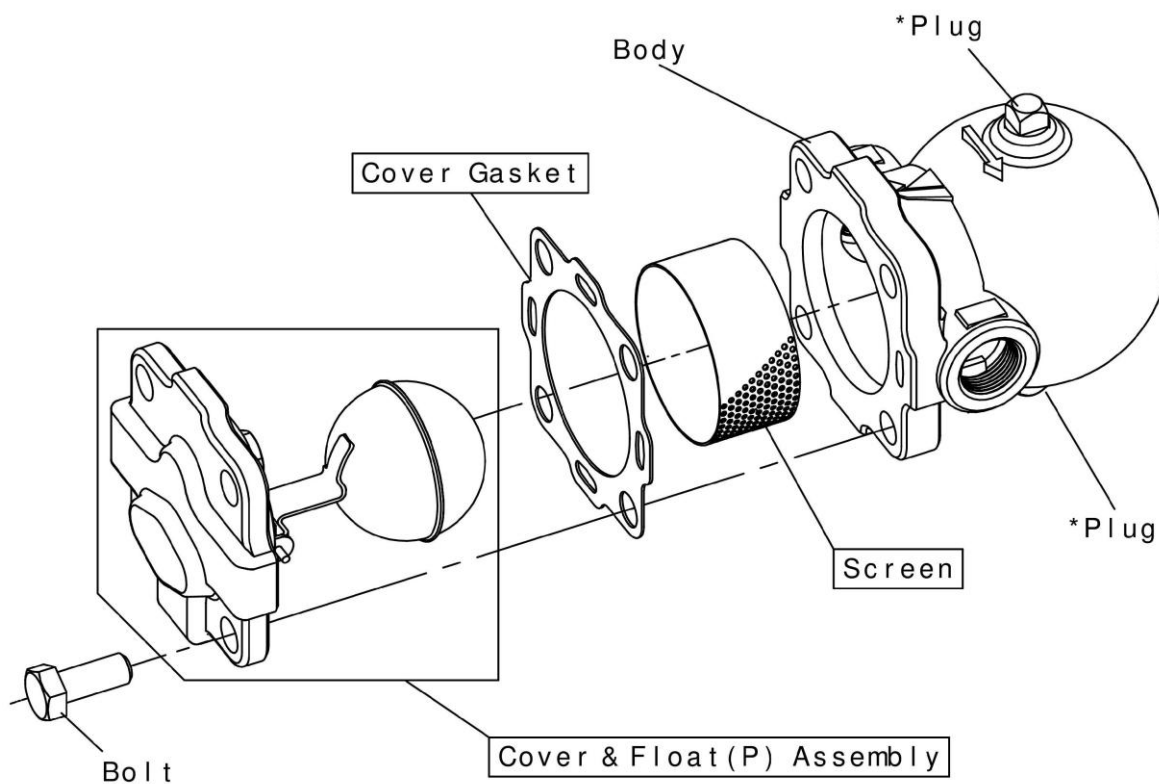

Cover & Float (P) Assembly

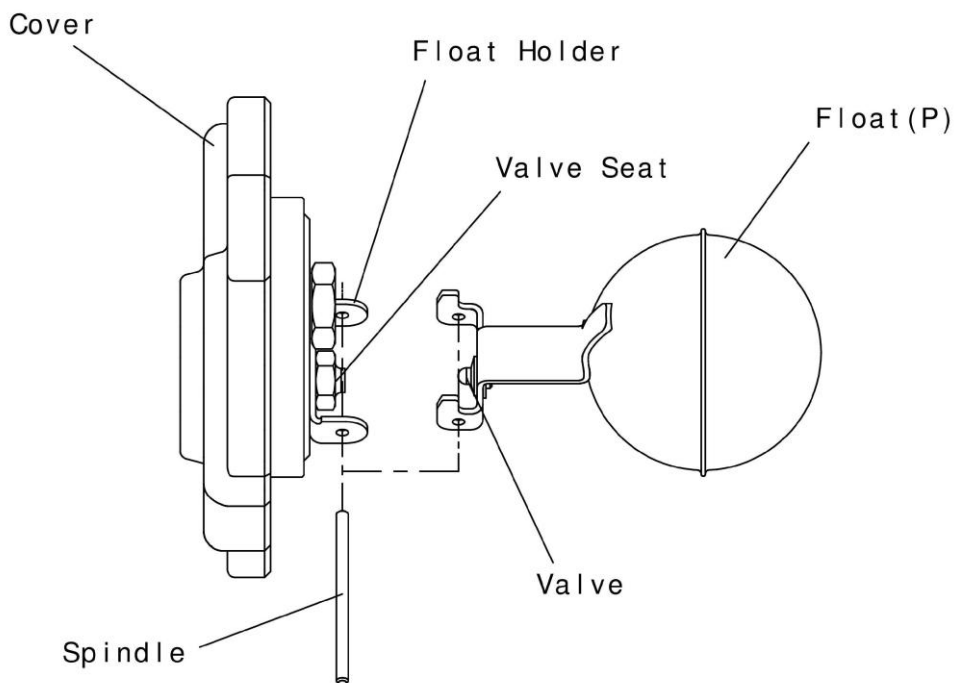

6.5 Disassembly

- Tools to be used

Name of tool	Size (Nominal size)
Ring wrench	19 mm

[Procedure 1] Loosen the bolts fixing the cover with ring wrench (width across flat: 19 mm), and remove the cover and gasket from the body. Pull out the screen from the body.

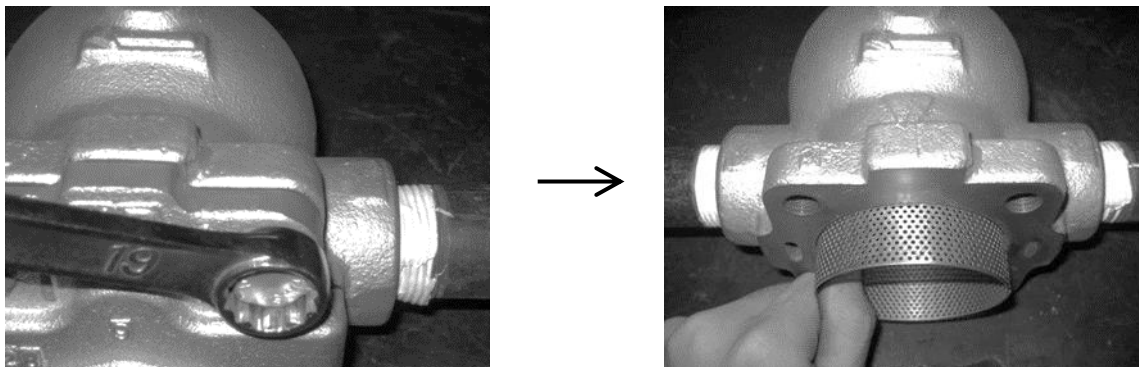

6.6 Reassembly

- Tools to be used

Name of tool	Size (Nominal size)
Torque Wrench	* Tightenable with torque of 45 N·m Width across flat: 19 mm

[Procedure 1] Connect the float holder and float (P) assembly with the spindle. Check that the float (P) assembly moves smoothly, and that the seat surface of the valve is in contact with that of the valve seat.

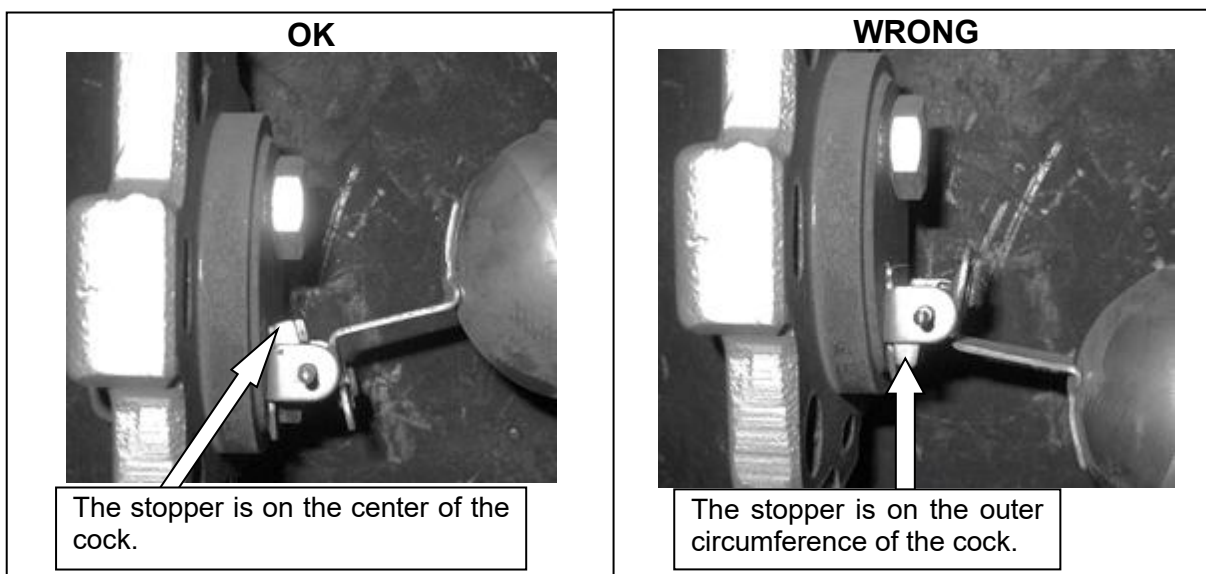

[Procedure 2] Attach the screen to the body. The screen can be inserted from either end.

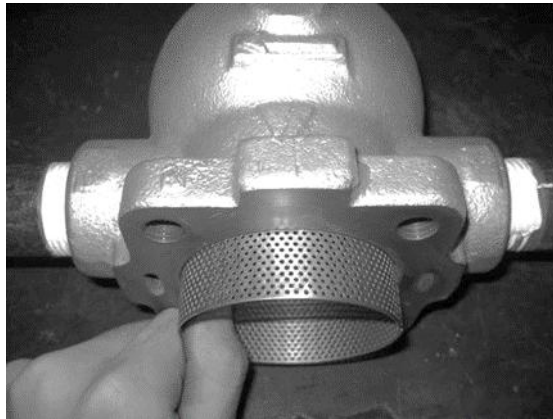

[Procedure 3] Install the cover gasket to the cover. Make the oval-shaped holes on the cover and on the cover gasket in the same position. Make sure to use a new cover gasket. Apply lubricant agent to the cover gasket (Recommendation: SOLVEST No.110 paste, STT Inc.).

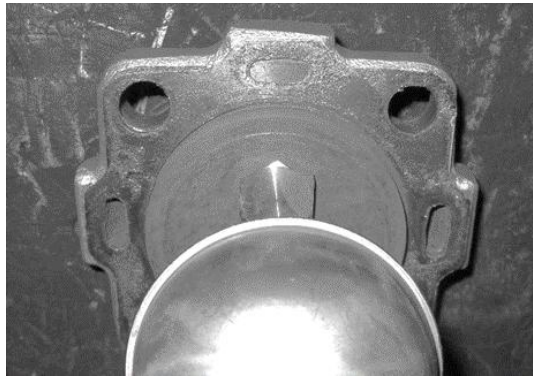

[Procedure 4] Install the cover to the body. Tighten the bolt with torque wrench (width across flat: 19 mm) with torque of 45 N·m.
* Do not use impact wrench to tighten the bolt. Using it may cause unevenly tightened bolt or damaged gasket, resulting in outside leakage.

