

MODEL SY-9 STRAINER

PRODUCT MANUAL

Thank you very much for choosing the Yoshitake's product. To ensure the correct and safe use of the product, please read this manual before use. This manual shall be kept with care for future references.

The symbols used in this manual have the following meanings.



	Warning	This symbol indicates a potentially hazardous situation that, if not avoided, could result in death or serious injury.
	Caution	This symbol indicates a hazardous situation that, if not avoided, may result in minor or moderate injury or may result in only property damage.

Table of Contents

1. Features	1
2. Specifications.....	1
3. Dimensions and Weights	1
4. Operation	2
5. Nominal Size Selection	2
5.1 Selection of nominal size	2
5.2 Selection of nominal pipe size.....	2
5.3 Nominal size selection chart	3
6. Installation	3
6.1 Piping example	3
6.2 Precautions during installation	4
7. Operating Procedure	4
7.1 Precautions during operation	4
8. Maintenance	5
8.1 Troubleshooting.....	5
8.2 Precautions during maintenance and inspection.....	5
8.3 Disassembly	6
8.4 Precautions during reassembly	6
8.5 Reassembly.....	6
8.6 Exploded view.....	7
Warranty Information	

1. Features

The product is widely used for dust removal in various type of pipelines. Easy plug is installed on the cap to secure the safety during maintenance.

2. Specifications

Application		Air, Cold and hot water, Other non-dangerous fluids
Max. pressure		1.0 MPa
Max. temperature		80°C
Material	Body	Ductile cast iron (FCD450)
	Screen	Stainless steel
	O ring	FKM
	Cap	C3604 (Brass)
Connection		JIS Rc screwed

- Standard screen: $\phi 2.5-7.21$ holes/cm² perforations with 60 mesh filter
- The products with 20 to 100 mesh filter are also available upon request.



Caution

Please confirm that the indications on the product correspond with the specifications of the ordered product model before use.
* Please consult factory in case they do not match each other.

3. Dimensions and Weights

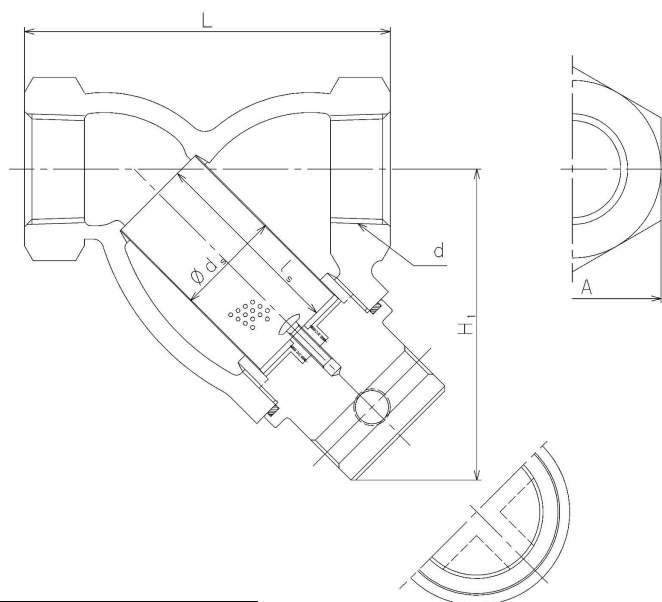

(mm)

d	L	H ₁	ds	ls	A	Weight(kg)
Rc 1/2	75	70	20	35	21.8	0.7
Rc 3/4	90	84	25	50	26.8	0.9
Rc 1	110	96	32	60	30	1.7
Rc 1 1/4	135	114	40	70	36	2.8
Rc 1 1/2	145	120	45	75	41	4.0
Rc 2	170	131	56	90	46	5.1

4. Operation

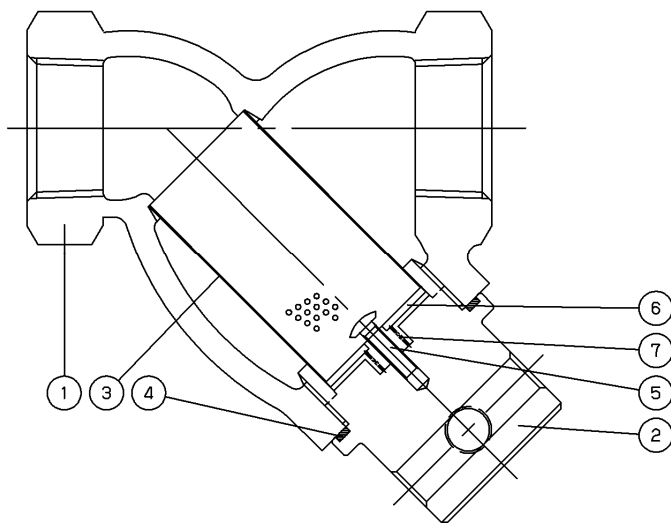

No.	Part Name
1	Body
2	Cap
3	Screen
4	O Ring
5	Cross recessed head screws
6	Spacer
7	Spring

Dust, scale, and other foreign substances flowing into the product through the inlet port are removed by the screen ③.

5. Nominal Size Selection

To make the best use of the product and to satisfy the operating requirements to the maximum, take notice of the following.

5.1 Selection of nominal size

Select a nominal size of the product equivalent to that of the pipe (nominal pipe size = nominal size of strainer). Note that use of a smaller nominal size increases the pressure loss through the strainer, and may possibly reduce the equipment inlet pressure below the specified limit.

5.2 Selection of nominal pipe size

When selecting an appropriate nominal pipe size, it is necessary to consider fluid type, maximum flow rate, permissible pressure loss, costs of piping and equipment, etc. If the nominal pipe size is smaller, the costs of piping and equipment decreases while the pressure loss through the pipe increases to generate disturbances, possibly resulting in pipe wear, noise and/or vibration. If the nominal pipe size is too large, not only the costs of piping and equipment but also the thermal loss increases. As a reference, the standard flow velocity is specified in the Japanese Industrial Standards (JIS) as a guide to select an appropriate nominal pipe size. See the following table.

<<Standard flow velocity>>

Fluid	Remarks	Standard flow velocity
Air	Lower pressure	15 m/s [5-15]
	Extremely low pressure: 0.1 MPa or less	10 m/s [3-10]
Water		2 m/s [2- 4]

* This table is based on the requirements provided in JIS F 7101 [Shipbuilding – Pipes of machinery – Standard velocity of flow].

5.3 Nominal size selection chart [Fluid: Water]

Screen: $\phi 2.5$ -7.21 holes/cm² perforations with 60 mesh filter

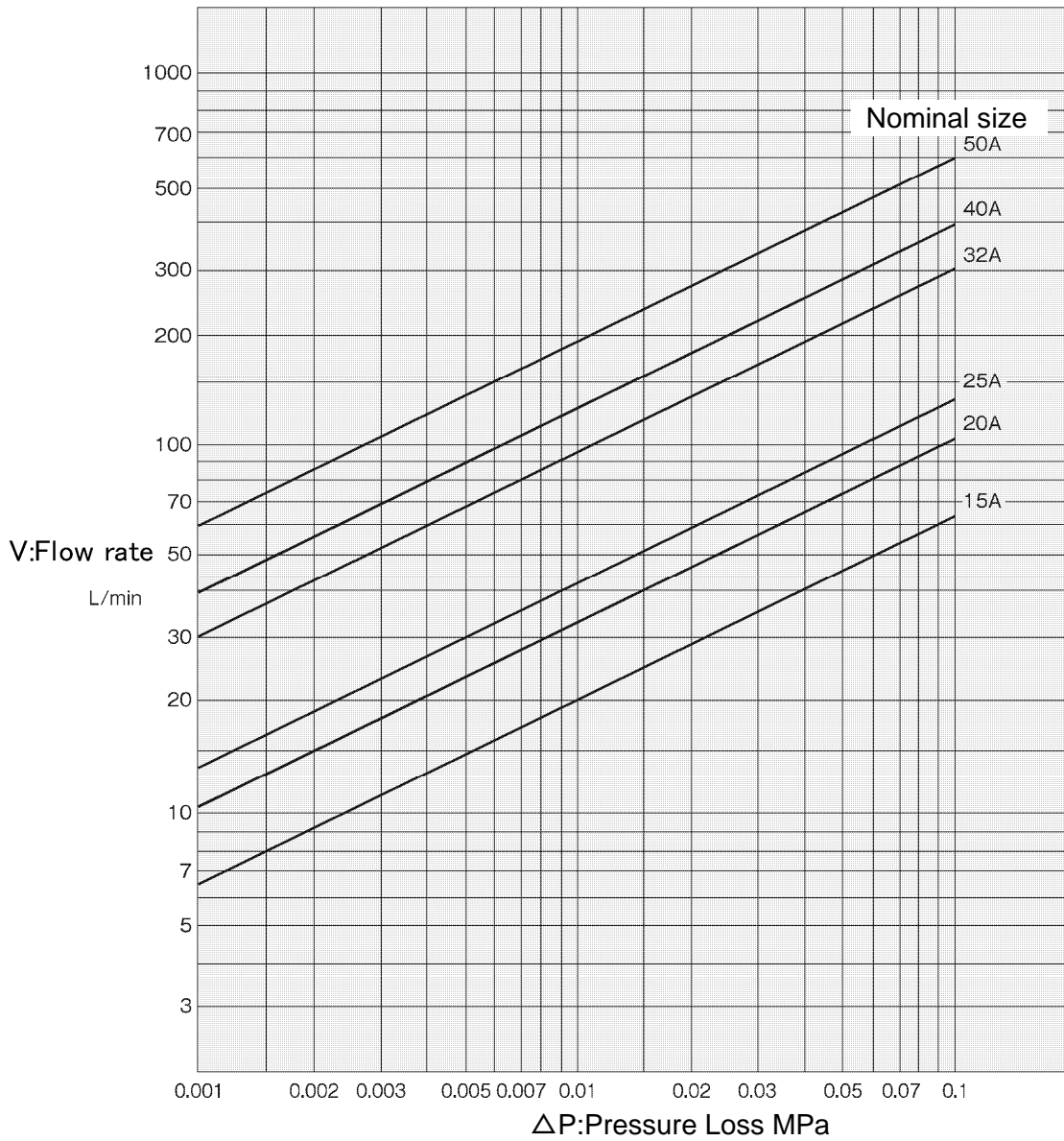

6. Installation

6.1 Piping example

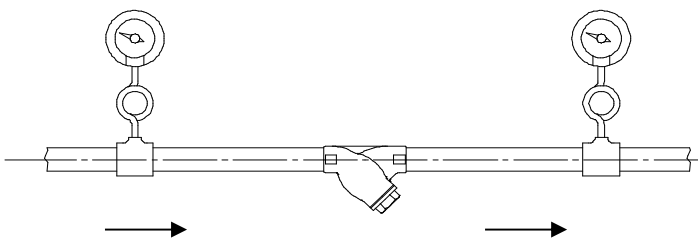

Fig. 1 Horizontal piping

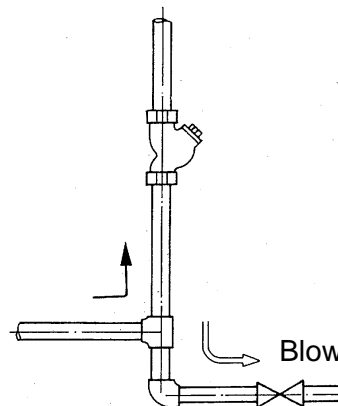

Fig. 2 Vertical piping

6.2 Precautions during installation

Caution

1. When installing, check the direction of the product so that the fluid flowing and the arrow marked on the product are in the same direction.
 - * Setting the product in wrong directions prevents the product from performing as intended.
2. When installing, enable the operator to pick up the screen from the product by reserving a working space required, as shown in the table below, for maintenance and inspection (cleaning of the screen).
 - * Failure to reserve a working space prevents maintenance and inspection (cleaning of the screen).
3. Connect the product to the pipes securely.
 - * Improper connecting may cause fluid leakage from the pipes when vibration is applied to them, resulting in scalds.

Maintenance dimensions	
Size	H(mm)
15A	80
20A	100
25A	110
32A	130
40A	140
50A	160

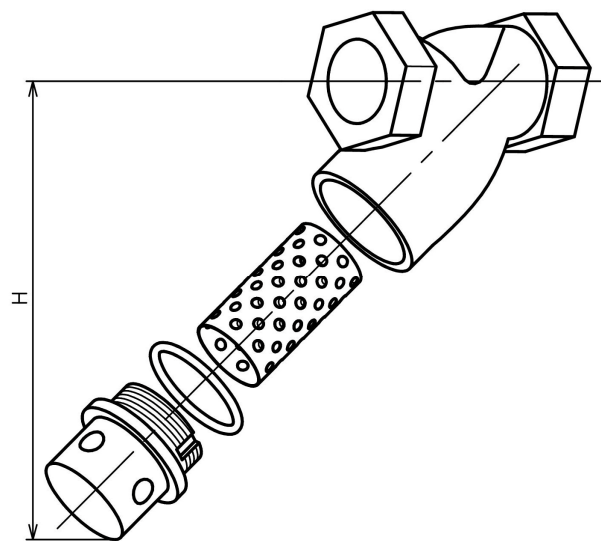

7. Operating Procedure

7.1 Precautions during operation



Warning

Before letting the fluid into the product, make sure that there is no possibility of danger when the fluid flows into the ends of piping.

- * The hot fluid, if spouted out, may scald your skin.
- * The fluid outflow may cause physical damage.



Caution

Use the product with a maximum pressure loss below 0.1 MPa. Periodically clean the screen.

- * Failure to follow this notice may damage the screen.

Clogging can be monitored when pressure gauges are installed both in upstream and downstream of the strainer.

8. Maintenance

8.1 Troubleshooting

Trouble	Cause	Remedy
Fluid does not flow.	1. Screen ③ is clogged.	1. Disassemble the product and clean the screen ③.
	2. Stop valves in upstream and downstream are closed.	2. Open the stop valves.
Excessive pressure loss	1. Screen ③ is clogged.	1. Disassemble the product and clean the screen ③.
	2. Pressure gauge is out of order.	2. Replace the pressure gauge with a new one.
	3. Nominal size of the product is too small for the piping	3. Replace the product with a new one proper for the piping nominal size.
Leakage from the cap	1. O ring is damaged.	1. Replace New O ring.
	2. Cap is loose.	2. Tighten with the specified torque value.

8.2 Precautions during maintenance and inspection

⚠ Warning
<p>1. Completely discharge the pressure inside of the product and piping prior to disassembly and inspection. When fluid is hot, cool down the product to the condition that it can be touched with bare hands. * Failure to follow this notice may result in scalds or injury due to the residual pressure.</p> <p>2. When the product is used for hot fluid, do not touch the product with bare hands. * The product having hot fluid may scald your skin.</p> <p>3. When removing the cap, fluid flows out after loosening the cap by 1 to 3 turns. When the product is used for hot fluid, cool down the product to the condition that it can be touched with bare hands. (Refer to the following [figure -3].) * Hot fluid may scald your skin.</p>

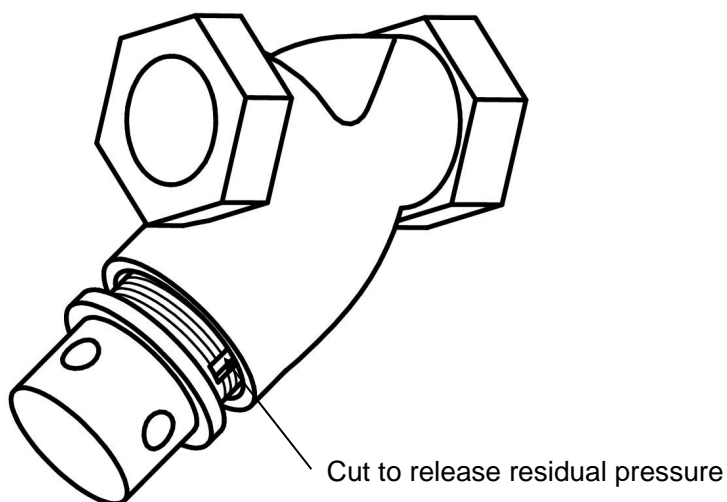

【figure -3】

8.3 Disassembly

Before disassembly, make sure that internal pressure has been completely released from the product and the piping,

- (1) Remove the cap ②. When the cap ② is strongly tightened, loosen it by applying a driver to a hole on the side of the cap ②.
(Notice: Please check “8.2 Precautions during maintenance and inspection” prior to removing the cap.)
- (2) Remove the screen ③ from the body ①.
- (3) Clean the screen ③ with compressed air or detergent.

8.4 Precautions during reassembly



Caution

1. When reassembling, connect all the parts securely.
* Failure to follow this notice may result in deformed or broken parts.
2. When reassembling, replace the O ring with a new one, and securely fasten the cap.
(Refer to the following list of O ring size.)
* Failure to follow this notice may result in fluid leakage, and may also scald your skin if the fluid is hot.

Nominal size	Size of O Ring
15A	P26
20A	P32
25A	P40
32A	G50
40A	G55
50A	G65

【O Ring Size】

8.5 Reassembly

Reassemble the product with the opposite procedures of disassembly (see 8.3 “Disassembly”). Refer to the following torque value for tightening the cap②.

Nominal size	Specified torque value(N·m)
15A	6
20A	6
25A	6
32A	10
40A	10
50A	20

【Specified torque value】

8.6 Exploded view

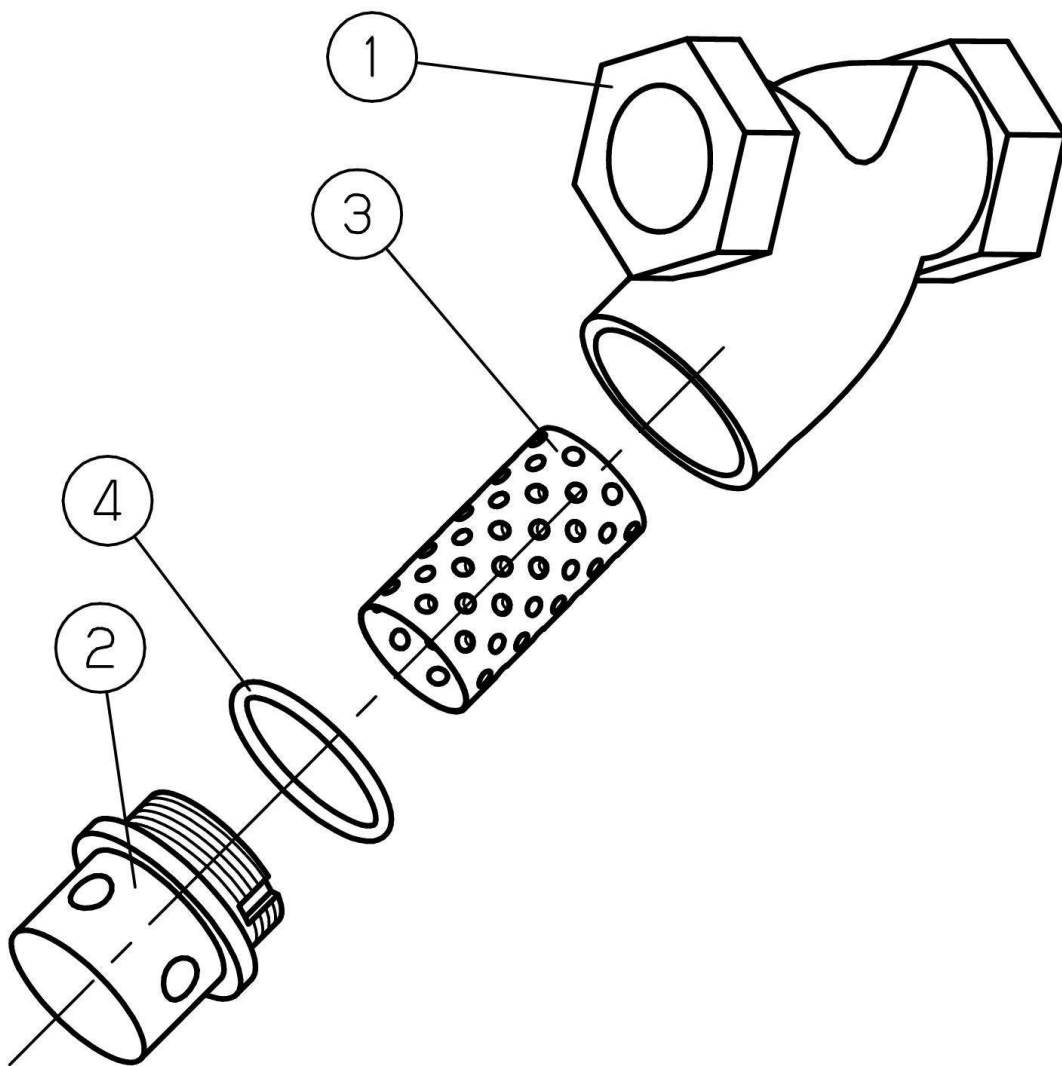

Warranty Information

1. Limited warranty

This product has been manufactured using highly-advanced techniques and subjected to strict quality control. Please be sure to use the product in accordance with instructions on the manual and the label attached to it.

Yoshitake warrants the product to be free from any defects in material and workmanship under normal usage for a period of one year from the date of receipt by the original user, but no longer than 24 months from the date of shipment from Yoshitake's factory.

2. Parts supply after product discontinuation

This product may be subject to discontinuation or change for improvement without any prior notice. After the discontinuation of the product, Yoshitake supplies the repair parts for 5 years otherwise individually agreed.

3. This warranty does not cover the damage due to any of below:

- (1) Valve seat leakage or malfunction caused by foreign substances inside piping.
- (2) Improper handling or misuse.
- (3) Improper supply conditions such as abnormal water pressure/quality.
- (4) Water scale or freezing.
- (5) Trouble with power/air supply.
- (6) Any alteration made by other than Yoshitake.
- (7) Use under severe conditions deviating from the design specifications (e.g. in case of corrosion due to outdoor use).
- (8) Fire, flood, earthquake, thunder and other natural disasters.
- (9) Consumable parts such as O-ring, gasket, diaphragm and etc.

Yoshitake is not liable for any damage or loss caused by malfunction or defect of the product.

YOSHITAKE

INTERNATIONAL DEPT.

955-5, Miyamae, Irukadeshinden, Komaki, Aichi, 485-0084, Japan

Phone: +81-568-75-4432 Fax: +81-568-75-4763

E-mail: Intntl@yoshitake.co.jp