



# MODEL OB-3,4,3G,4G

# TEMPERATURE REGULATOR VALVE

Thank you very much for choosing the Yoshitake's product. To ensure the correct and safe use of the product, please read this manual before use. This manual shall be kept with care for future references. The symbols used in this manual have the following meanings.

	<b>Warning</b>	This symbol indicates a potentially hazardous situation that, if not avoided, could result in death or serious injury.
	<b>Caution</b>	This symbol indicates a hazardous situation that, if not avoided, may result in minor or moderate injury or may result in only property damage.

---

## Table of Contents

---

1. Usage of the Product .....	1
2. Specifications .....	1-2
2.1 Specifications .....	1
2.2 Temperature adjusting range .....	2
2.3 Temperature accuracy from set point .....	2
2.4 Cv value table .....	2
2.5 Valve Seat Leakage .....	2
3. Dimensions and Weight .....	3-4
4. Nominal Size Selection Chart .....	5-6
5. Maintenance and Inspection .....	7-10
5.1 Cautions before use .....	7
5.2 Installation of Main Unit .....	7
5.3 Installation of Thermal bulb .....	8
5.4 Warnings and Cautions for Use .....	8
5.5 Adjustment Procedures .....	9
5.6 Example of piping .....	9
5.7 Trouble and Corrective Actions .....	10
5.8 Precautions during maintenance and inspection .....	10
5.9 How to Disassemble .....	10
6. Handling of Protection Pipe (Option) .....	11-12
Warranty Information	

# YOSHITAKE

## 1. Usage of the Product

The automatic temperature adjustment valves, OB-3, OB-3G, OB-4 and OB-4G, are used in the systems for ocean vessels, industrial plants, air conditioning equipment, chemical industry, etc. for adjusting the cooling temperature.

## 2. Specifications

### 2.1 Specifications

Model		OB-3	OB-3G
Nominal size		15-40A	
Application	Heating	Cold water, Refrigerant	
	Heated	Cold and hot water, Oil, Non-dangerous fluid	
Maximum Pressure	Body	0.7MPa	
	Thermal bulb	1.0MPa	
Max. temperature		180 °C	
Temperature adjusting range	For liquid	40-120 °C	15-100 °C
	For air		
Ambient temperature		Set temperature -10°C or less	Set temperature +30°C or less
Material	Body	bronze	
	Valve, Valve seat	bronze	
	Valve spindle	Stainless steel	
	Bellows	Phosphor bronze	
	Thermal bulb	For liquid	Stainless steel
For air		Stainless steel	
Standard capillary length		2m	
Connection		JIS Rc screwed (union joint)	

Model		OB-4	OB-4G
Nominal size		15-150A	15-125A
Application	Heating	Cold water, Refrigerant	
	Heated	Cold and hot water, Oil, Non-dangerous fluid	
Maximum Pressure	Body	15-40A:0.7MPa [1.0MPa] 50A:0.5MPa [0.7MPa] 65A:0.5MPa [0.7MPa] 80A:0.4MPa [0.5MPa] 100A:0.4MPa 125A:0.2MPa [0.35MPa for OB-4] 150A:0.2MPa	
		Thermal bulb	1.0MPa
Max. temperature		180 °C	
Temperature adjusting range	For liquid	40-120 °C	15-100 °C
	For air		
Ambient temperature		Set temperature -10°C or less	Set temperature +30°C or less
Material	Body	Cast iron	
	Valve, Valve seat	bronze (stainless steel)	
	Valve spindle	Stainless steel	
	Bellows	Phosphor bronze	
	Thermal bulb	For liquid	Stainless steel
For air		Stainless steel	
Standard capillary length		15-80A:2m 100-150A:3m	
Connection		JIS 10K FF flange	

- If the ambient temperature is higher than the set temperature or less than 40°C, use the OB-4G (with external pressure type bellows).
- If using at a pressure higher than 0.5 MPa, with stainless steel trim parts is recommended.
- Available with capillary of up to 5 meter.
- Available with Max. pressure inside [ ] (Valve and valve seat material, and bellows is different from standard type).
- Available with thermal well (SUS304 made or with a PTFE cap) for liquid.

## 2.2 Temperature adjusting range

### OB-3,4

Temperature adjusting range(°C)		Withstand temperature (°C)
For liquid	For air	
40-60	40-60	70
50-70	50-70	80
60-80	60-80	90
80-100	80-100	110
100-120	100-120	130

The term "Withstand temperature" means the temperature from pressure resistance of the bellows.

### OB-3G,4G

Temperature adjusting range(°C)		Withstand temperature (°C)
For liquid	For air	
15-35	15-35	50
20-40	20-40	50
35-55	35-55	70
40-60	40-60	90
50-70	50-70	100
60-80	60-80	110
70-90	70-90	120
80-100	80-100	130

## 2.3 Temperature accuracy from set point

As below, depending on capillary length

Standard capillary length	OB-3·4		OB-3G·4G
	For liquid	For air	For liquid, For air
2m	± 2°C	± 3°C	± 3.5°C
2-3.5m	± 2.5°C	± 3.5°C	± 4°C
3.5-5m	± 3°C	± 4°C	± 4.5°C

· If the preset temperature is higher than 100°C, add ±1.0°C.

· The preset temperature error is the maximum temperature width ranging from the time when the valve closes until the time when the valve starts to open, not the value expressing the control width.

## 2.4 Cv value table

Nominal size	15A	20A	25A	32A	40A	50A	65A	80A	100A	125A	150A
OB-3·3G	2	2	4	7	10	—	—	—	—	—	—
OB-4	2	2	4	7	10	14	21	27	42	72	94
OB-4G	2	2	4	7	10	14	21	27	42	72	—

## 2.5 Valve Seat Leakage

Unit: steam (kg/h), water (L/h)

Nominal size	15A	20A	25A	32A	40A	50A	65A	80A	100A	125A	150A
OB-3·3G	1.5	1.5	1.8	2.4	3.0	—	—	—	—	—	—
OB-4	1.5	1.5	1.8	2.4	3.0	3.6	4.8	6.0	7.2	9.0	10.8
OB-4G	1.5	1.5	1.8	2.4	3.0	3.6	4.8	6.0	7.2	9.0	—

· The values in the table above are max. Valve seat leakage is measured under the condition of 0.5MPa or max.pressure. at the temperature of "set temperature-5°C" for cooling.

### 3. Dimensions and Weight

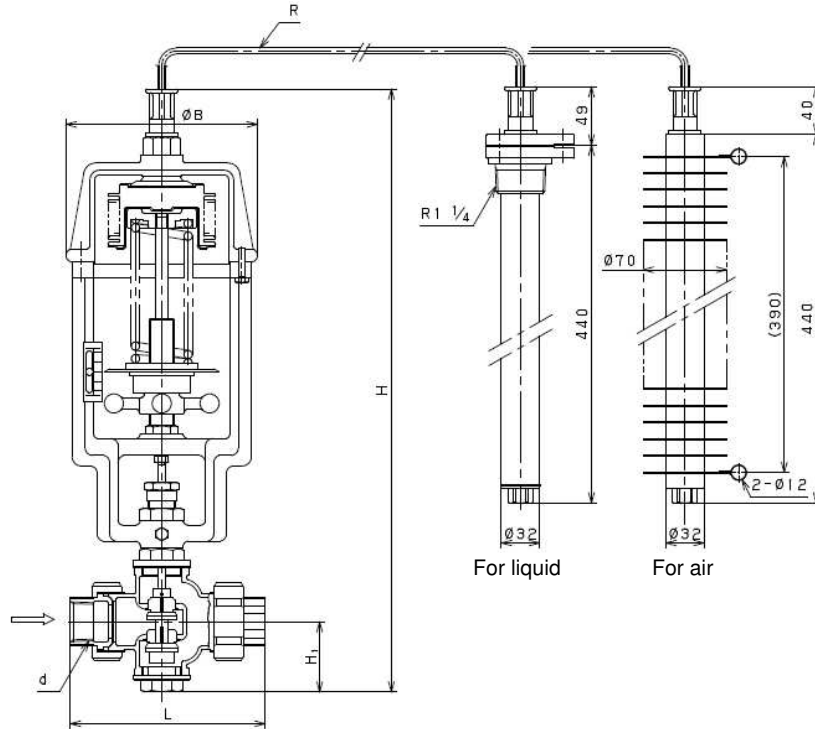

OB-3-3G

OB-3G has a little difference in bellows structure.

(mm)

Nominal size	d	L	H <sub>1</sub>	H	B	Weight (kg)
15A	Rc 1/2	148	55	510	160	11
20A	Rc 3/4	148	55	510	160	11
25A	Rc 1	160	60	520	160	12
32A	Rc1 1/4	195	60	520	160	12
40A	Rc1 1/2	210	65	530	160	13

(mm)

	Nominal size	R
Standard	15A-40A	2000

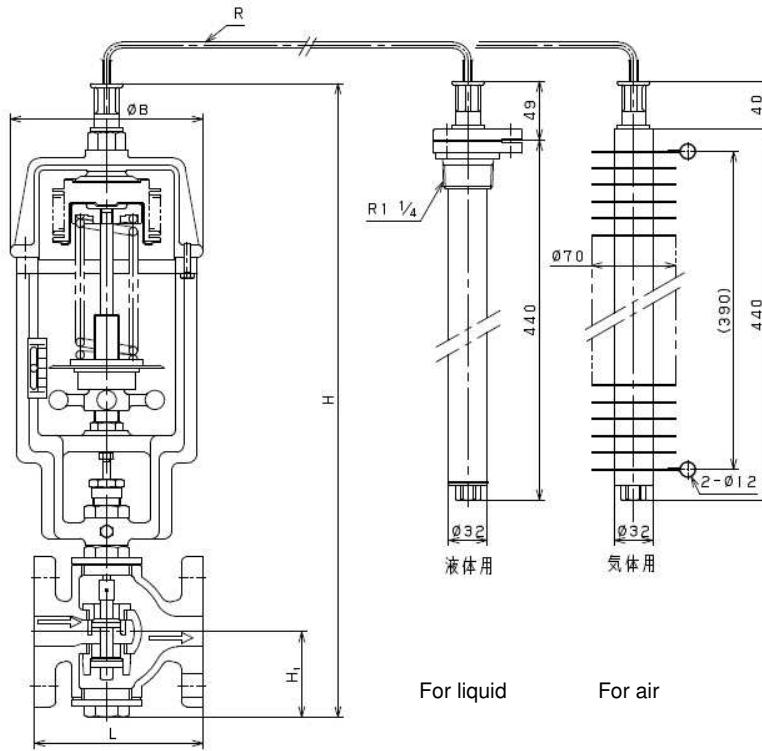

OB-4-4G

OB-4G has a little difference in bellows structure.

(mm)

Nominal size	L	H <sub>1</sub>	H	B	Weight(kg)
15A	126	60	520	160	15
20A	130	60	520	160	16
25A	140	70	540	160	18
32A	150	75	550	160	21
40A	160	75	550	160	23
50A	180	110	620	160	29
65A	215	125	650	160	38
80A	260	135	670	160	48
100A	300	160	750	180	58
125A	360	190	810	180	76
150A *1	382	220	980	220	125

(mm)

	Nominal size	R
Standard	50-80A	2000
	100-150A *1	3000

\*1: The OB-4G comes in nominal size up to 125A.

## 4. Nominal Size Selection Chart

● OB-3-3G (For Water)

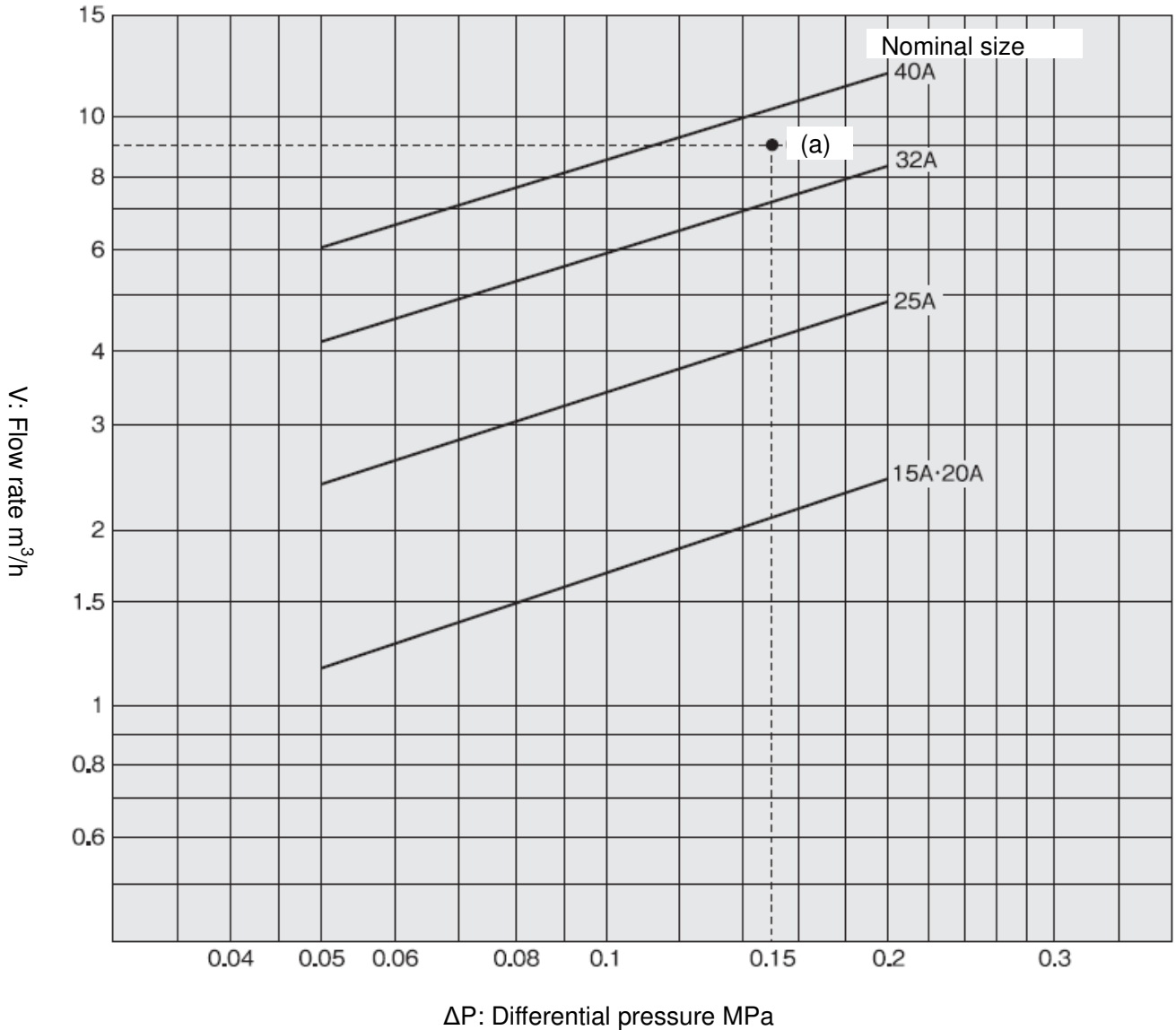

### How to use chart

When selecting the nominal size of a temperature regulator whose inlet pressure (P1), outlet (P2), and steam flow rate are 0.3MPa, 0.15MPa, 9 m³/h, respectively, first find intersection point (a) of the differential pressure = 0.15MPa (0.3MPa-0.15MPa) and the flow rate = 9 m³/h. Since the intersection point (a) lies between nominal size 32A and 40A, select the larger one, 40A.

● OB-4·4G (For Water)

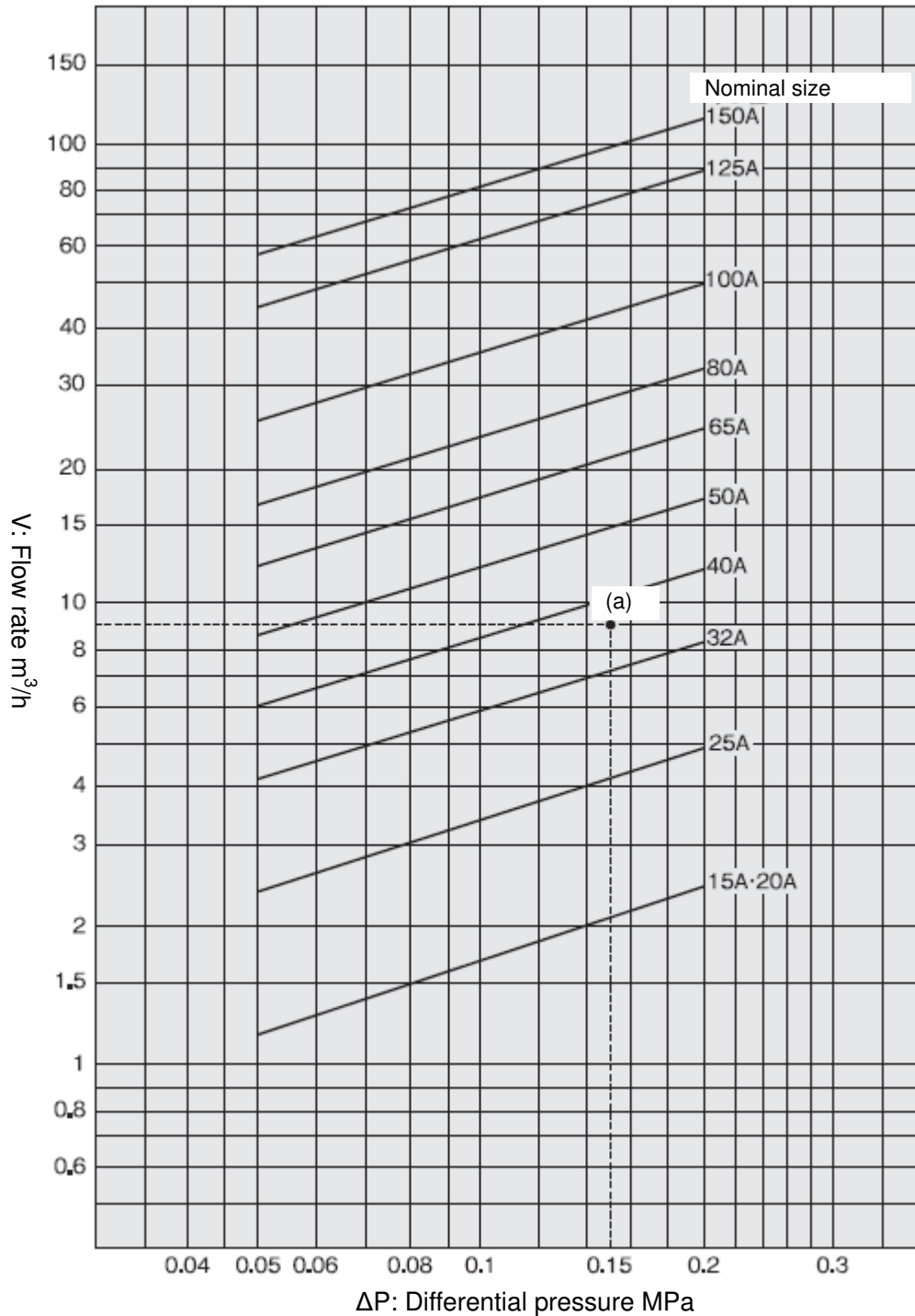

**How to use chart**

When selecting the nominal size of a temperature regulator whose inlet pressure (P1), outlet (P2), and steam flow rate are 0.3MPa, 0.15MPa, 9 m<sup>3</sup>/h, respectively, first find intersection point (a) of the differential pressure = 0.15MPa (0.3MPa-0.15MPa) and the flow rate = 9 m<sup>3</sup>/h. Since the intersection point (a) lies between nominal size 32A and 40A, select the larger one, 40A.

---

## 5. Maintenance and Inspection

---

### 5.1 Cautions before use

 **Caution**

- (1) Do not disassemble the product without reason.
  - \* If you disassemble the product for no reason, the original performance of the product is not achieved.
- (2) When plumbing the product, make sure to remove foreign substances, scale, etc. from the pipes.
  - \* If foreign substances, scale, etc. enter the product, the original performance of the product is not achieved.
- (3) Make sure to install a strainer (60 to 80 mesh) on the inlet side of the product.
  - \* If foreign substances, scale, etc. enter the product, the original performance of the product is not achieved.
- (4) Install pressure gauges on the inlet and outlet sides of the product to confirm the operation of the product.
  - \* Otherwise, the temperature is not adjusted correctly and, therefore, the original performance of the product is not achieved.
- (5) To install the product, confirm the inlet, outlet and posture of the product.
  - \* If the product is installed in a wrong way, it may not perform its original functions.
- (6) Install the product in a place where the temperature does not exceed the preset temperature.
  - \* If the ambient temperature becomes higher than the present temperature, the temperature cannot be adjusted correctly.
- (7) Install a thermometer near the thermal bulb.
  - \* Otherwise, the temperature cannot be adjusted correctly.
- (8) Install the thermal bulb in a way that makes three fourths or more of its total length come into contact with the fluid to be heated.
  - \* Otherwise, the temperature cannot be adjusted correctly and the original performance of the product is not achieved.
- (9) Make sure that the installation posture of the thermal bulb is correct. If there are T marks on the flanges or joint nuts, follow the instructions on how to install them.
  - \* Otherwise, the temperature cannot be adjusted correctly.
- (10) The bending radius of the capillary tube must be 40 mm or more. Do not bend it at an acute angle, nor twist it or pull it forcibly.
  - \* Otherwise, the capillary tube may be damaged and the original performance of the product is not achieved.
- (11) Make sure that the capillary tube is not in contact with the steam pipe.
  - \* Otherwise, the temperature cannot be adjusted correctly and the original performance of the product is not achieved.
- (12) Install pipes in a way that does not add excessive load, bending force, vibration, etc. on the product.
  - \* Otherwise, the product may not function correctly or the service life of the product may be extremely shortened.

### 5.2 Installation of Main Unit

- (1) Install the temperature regulator valve vertically against the horizontal pipe, placing its frame above.
- (2) If the ambient temperature becomes higher than the preset temperature, it may cause malfunction of the product, so install the product in a place where the temperature does not exceed the preset temperature.
- (3) Make sure to install a pressure gauge and a strainer bypass pipe in the piping. (See 6.6 Piping Diagram.)
- (4) If the pressure of the heating fluid is higher than the maximum pressure, use the product after reducing the pressure with the pressure reduction valve, etc.
- (5) Implement the plumbing in a way that does not add excessive load, bending force, vibration, etc. to the main unit.
- (6) If the product is to be left unused for a long time, completely drain the pipes and close the gate valves at the front and the rear of the temperature adjustment valve.
- (7) When supplying air or water, make sure to remove foreign substances from the pipes through the bypass pipe and then open the temperature adjustment valve circuit.

### 5.3 Installation of Thermal bulb

- (1) Avoid bending the capillary tube at a sharp angle, twisting or pulling it with force. Secure the capillary tube not to allow it touch steam piping or any other of high temperature. The bend radius of the capillary tube should be more than 40 mm.
- (2) Make sure that more than 3/4 of its total length is in direct contact with the fluid to be heated.
- (3) Install a thermometer close to the thermal bulb.
- (4) If the thermal bulb is to be inserted into a pipe to detect temperature, install it in a place where the circulation is the best.
- (5) To install the thermal bulb, first remove the mating flange bolts and screw in the screwing flange, then insert the thermal bulb, align it with the hole of the mating flange and fasten the bolts evenly. When doing this, make sure that the capillary tube is not twisted.
- (6) Install a thermal bulb in a posture in which the top of thermal bulb is higher than the other side (connecting part to the tube), and in which the marking (on flange or nut) is always at highest position.
- (7) Make sure that the thermal bulb's joint section does not incline downward and does not become lower than its tip. Plumb it in a way that makes the T mark position of the flange or joint nut come to the top. Note that if the installation angle is 90 degrees or 30 degrees or more against the horizontal pipe, the installation posture does not affect the function even if the installation is made regardless of the T mark position. (See the diagram below showing an example of thermal bulb insertion.)

**Thermal bulb installation example**

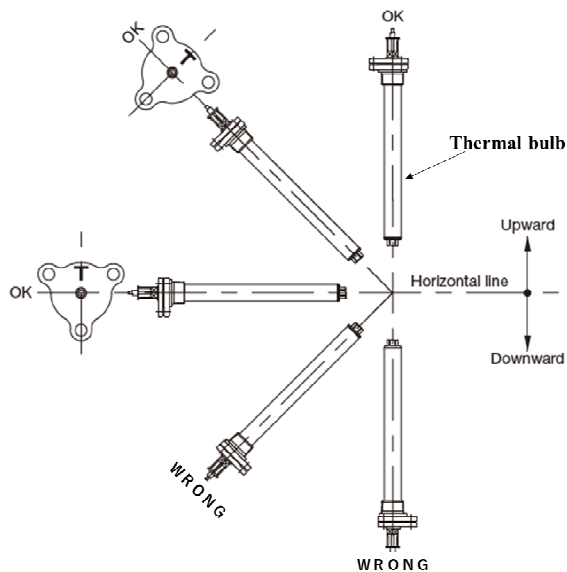

### 5.4 Warnings and Cautions for Use

#### **Warning**

- (1) In case of high temperature fluid, do not touch the product directly with bare hands.\* There is danger of scald.
  - (2) Do not fasten the gasket of the product additionally.
- \* The gasket may break and external leakage may occur.

#### **Caution**

- (1) When supplying air or water to the product, make sure to close the stop valves at the front and the rear of the product and remove foreign substances, scale, etc. completely through the bypass pipe. When blowing, do not increase the temperature higher than the heat resistance temperature.
- \* If foreign substances, scale, etc. enter the product, the original performance of the product is not achieved. If the temperature becomes higher than the heat resistance temperature, the valve shaft bends and becomes unusable.
- (2) To adjust the temperature, take your time to do so, watching the thermometer.
- \* Otherwise, correct adjustment is not obtained.
- (3) If the product is left unused for a long time, completely drain the fluid from the product or pipes and close the stop valves at the front and the rear of the product.
- \* Otherwise, rust may be formed in the product or pipes, causing malfunction of the product.
- (4) If drain stays in the product when closing the valves, install a trap and discharge the drain.
- \* Otherwise, rust may be formed in the product or pipes, causing malfunction of the product.

## 5.5 Adjustment Procedures

Incorrect adjustment may cause hunting, scale problems or water hammer, and may heavily damage the main parts of the product. Be sure to follow the steps below.

- (1) Close the stop valves at the front and the rear of the product. Open the bypass stop valve and blow fluid through the bypass line with enough time. After discharging, be sure to close the bypass stop valve. While blowing, be careful not to apply fluid of higher temperature than the max. allowable temperature of the product.
- (2) Turn the handle and move the indicator to the desired temperature position on the scale. To raise the temperature, turn the handle counterclockwise (when seen from the top). To lower the temperature, turn it clockwise (when seen from the top). Reading scale is only for reference, so please adjust the temperature by using a thermometer.
- (3) Slowly open the inlet stop valve to its full open position, and then, open the outlet stop valve little by little to its full open position.
- (4) Adjust the handle till the desired temperature is obtained while watching the thermometer with enough time.

## 5.6 Example of piping

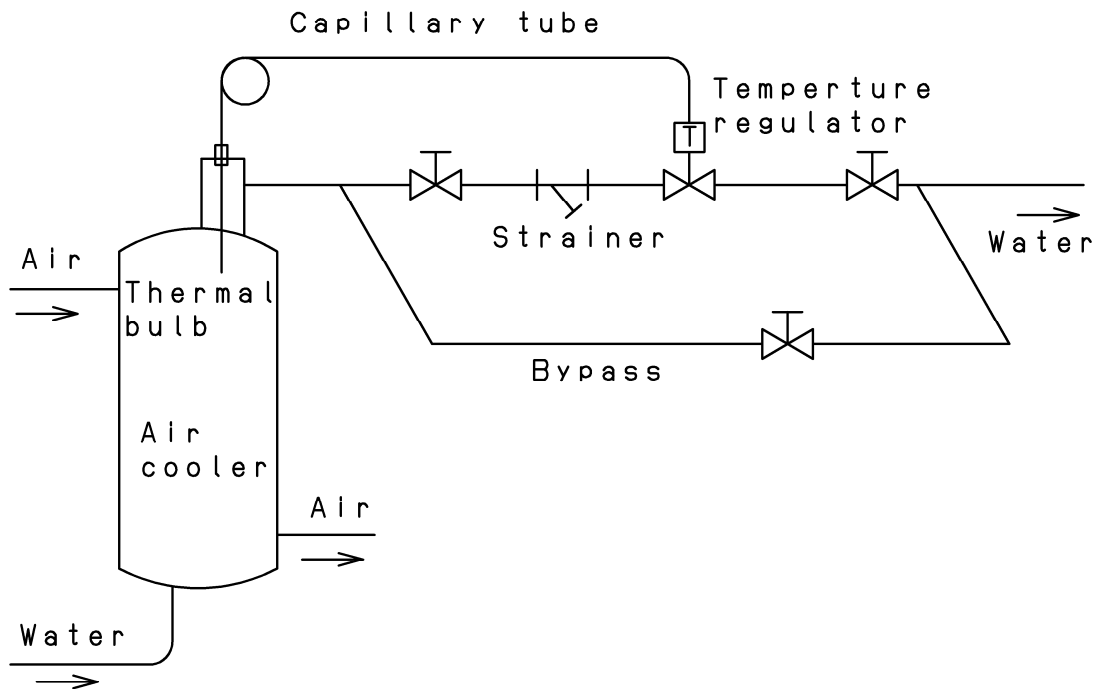

## 5.7 Trouble and Corrective Actions

Trouble	Cause	Remedy
temperature does not rise.	<ol style="list-style-type: none"> <li>1. Inadequate adjustment.</li> <li>2. Nominal size of the product is too small for the specifications of the system.</li> <li>3. Temperature range of sensor is not proper.</li> <li>4. The temperature around the temperature adjustment valve is higher than the preset temperature.</li> <li>5. Insufficient drainage from the trap of heat exchanger.</li> </ol>	<ol style="list-style-type: none"> <li>1. Readjust according to the adjustment procedures.</li> <li>2. Replace the product with one of proper nominal size.</li> <li>3. Check the label and replace the sensor.</li> <li>4. Install ventilation fans or windows to decrease the ambient temperature.</li> <li>5. Open the trap's by-pass line and check the condition.</li> </ol>
Temperature rises excessively.	<ol style="list-style-type: none"> <li>1. Inadequate adjustment.</li> <li>2. Foreign substances are stuck between main valve and main valve seat, or either of the parts is damaged.</li> <li>3. There is leakage from the bypass pipe.</li> <li>4. thermal bulb or bellows is damaged.</li> </ol>	<ol style="list-style-type: none"> <li>1. Readjust according to the adjustment procedures.</li> <li>2. Repair by the factory is necessary.</li> <li>3. Repair or replace.</li> <li>4. Replace the sensor.</li> </ol>
Large error of temperature control.	<ol style="list-style-type: none"> <li>1. Spindle and guide, or, pilot valve and guide do not move smoothly.</li> <li>2. bellows or valve shaft is deformed because of external shock or temperature higher than "withstand temperature".</li> <li>3. Thermal bulb and thermometer are installed in wrong positions.</li> </ol>	<ol style="list-style-type: none"> <li>1. Disassemble and clean, or replace.</li> <li>2. Replace the product.</li> <li>3. Reinstall them at points where the circulation is best.</li> </ol>

## 5.8 Precautions during maintenance and inspection



### Warning

- (1) When using a hot fluid, do not touch the product by bare hand.  
\*Doing so may scald your skin.
- (2) After aerating, do not retighten gasket.  
\* Doing so may break the gasket, possibly resulting in external leak.



### Warning

- (1) Do not disassemble the bellows when the thermal bulb is heated.  
\* If you do so, the bellows may be damaged and the original functions of the product are not realized.
- (2) Do not apply shock to the thermal bulb.
- (3) When disassembling a gasket, always replace it with new one.  
\*If an old gasket is used as is, the fluid may leak outside.

- (4) Alcohols or specified chlorofluorocarbon is sealed in the thermal bulb. So when disposing of the products, have a waste disposer collect and treat them. If you want us to do so, we undertake the service at cost. Contact our sales office for more information.

## 5.9 How to Disassemble

### (1) How to disassemble bellows

1. Take out the thermal bulb from the tank, chemical liquid tank or pipe area.
2. Turn the adjustment handle to the right (seen from above) and make the state in which the load from the adjustment spring is not applied on the product.
3. Remove the bolts holding bellows cover and take out the bellows from the main body.  
\* Never heat the thermal bulb with the bellows detached. In case of the thermal bulb for setting low temperature, follow the procedures described in section 3 above while cooling it in water.

---

## 6. Handling of Protection Pipe (Option)

---

### 6.1. A set of protection pipes



### 6.2 Insert a gasket into the protection pipe.

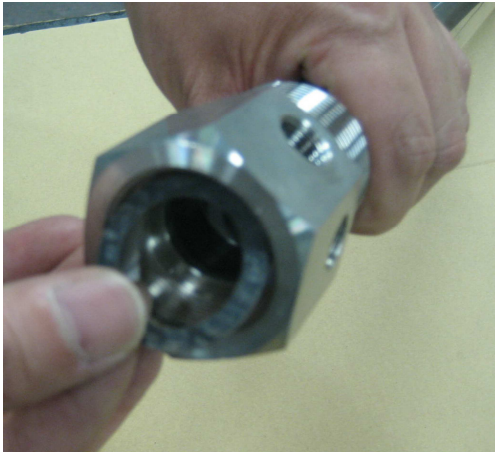

### 6.3 Insert a thermal bulb into the protection pipe and screw in a screwing joint.



**6.4 Fasten the joint nut with a wrench or spanner.**



**6.5 Inject liquid which is the same as the liquid to be heated from the plug hole on the screwing joint side.**



**6.6 Attach the plug after injection.**

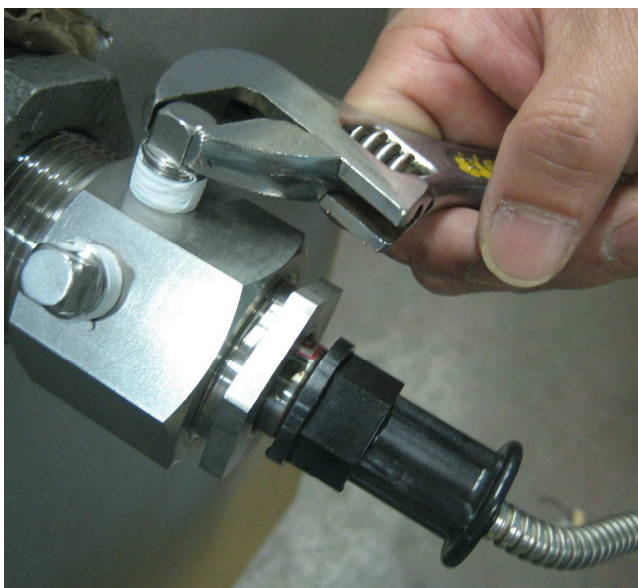

---

## Warranty Information

---

1. Limited warranty

This product has been manufactured using highly-advanced techniques and subjected to strict quality control. Please be sure to use the product in accordance with instructions on the manual and the label attached to it.

Yoshitake warrants the product to be free from any defects in material and workmanship under normal usage for a period of one year from the date of receipt by the original user, but no longer than 24 months from the date of shipment from Yoshitake's factory.

2. Parts supply after product discontinuation

This product may be subject to discontinuation or change for improvement without any prior notice. After the discontinuation of the product, Yoshitake supplies the repair parts for 5 years otherwise individually agreed.

3. This warranty does not cover the damage due to any of below:

- (1) Valve seat leakage or malfunction caused by foreign substances inside piping.
- (2) Improper handling or misuse.
- (3) Improper supply conditions such as abnormal water pressure/quality.
- (4) Water scale or freezing.
- (5) Trouble with power/air supply.
- (6) Any alteration made by other than Yoshitake.
- (7) Use under severe conditions deviating from the design specifications (e.g. in case of corrosion due to outdoor use).
- (8) Fire, flood, earthquake, thunder and other natural disasters.
- (9) Consumable parts such as O-ring, gasket, diaphragm and etc.

Yoshitake is not liable for any damage or loss caused by malfunction or defect of the product.

# YOSHITAKE

INTERNATIONAL DEPT.

955-5, Miyamae, Irukadeshinden, Komaki, Aichi, 485-0084, Japan

Phone: +81-568-75-4432 Fax: +81-568-75-4763

E-mail: [Intntl@yoshitake.co.jp](mailto:Intntl@yoshitake.co.jp)